



SELF RETRACTING DEVICE (SRD)

CSA Class SRL (Self Retracting Lifeline)



Meets or exceeds standards
and requirements established by:

CSA	Z259.2.2-17
ANSI	Z359.14
ANSI	A10.32
OSHA	1926.502

WARNING MESSAGES ARE INSERTED THROUGHOUT THE MANUAL AND HIGHLIGHT NECESSARY STEPS TO ENSURE SAFE WORKING CONDITIONS.

READ THESE WARNINGS FIRST

- The SRD is only part of a total fall protection system and the use of compatible hardware and components is mandatory. The system components must meet federal, state, local or provincial regulations before being incorporated in a personal fall protection system. If you have any concerns or questions, please contact your distributor or Safety Direct.
- Never clamp, knot or prevent the lifeline from retracting or being taut.
- Avoid working above the anchorage level to avoid an increased free fall distance.
- It is imperative for the safety and efficiency of operations that this manual be read and fully understood by the worker before using any fall arrest system. ALL instructions contained herein must be carefully read and strictly followed.
- A fall could result in serious injury or death. Do not use any equipment unless properly trained.
- The limit of one person only per fall arrest system must always be observed.
- Do not let go of the web/cable until it has completely rewound inside the SRD.
- The user must not exceed an angle of 30° and never move away from the vertical axis of the SRD for more than 10 ft. (3 m) (Figure 7).
- Care should be taken to avoid contact with all sharp edges which could cut the web/cable.
- Ensure adequate clearance exists in your fall path to prevent striking an object (Figure 4 and Figure 6). When the SRD is installed on a non-rigid anchor point, ensure the deflection of the system is taken into consideration within the calculation of the total clearance required.
- For all assembly configurations:
The anchoring to the structure must allow self-alignment of the SRD under the effect of the force exerted on the web/cable.

*WARNING - A FALL COULD RESULT IN SERIOUS INJURY OR DEATH.
DO NOT USE ANY EQUIPMENT UNLESS PROPERLY TRAINED.*

SRD RETRACTABLE USE AND MAINTENANCE INSTRUCTIONS

SRD Retractable Use and Maintenance Instructions	3
1. YOUR RESPONSIBILITY FOR COMPLIANCE	3
2. YOUR RESPONSIBILITY FOR INSPECTIONS	4
3. YOUR RESPONSIBILITY FOR TRAINING AND SUPERVISION	4
4. YOUR RESPONSIBILITY FOR COMPONENTS CONNECTED TO THE SRD	4
5. YOUR RESPONSIBILITY FOR RISK ASSESSMENT	4
6. DESCRIPTION	5
7. INSTALLATION ABOVE WORKER	5
8. INSTALLATION ON HARNESS	9
9. OPERATION	12
10. ENVIRONMENT	12
11. RESCUE	12
12. LIMITATION OF THE EQUIPMENT	13
13. INSPECTION	13
14. LABELLING	17
15. TROUBLESHOOTING	18
16. MAINTENANCE AND STORAGE	18
17. WARRANTY INFORMATION	18

1. YOUR RESPONSIBILITY FOR COMPLIANCE

- 1.1. It is the workers and their employers' responsibility to strictly conform to the following warnings.
- 1.2. In all circumstances, if a fall arrest system, or any of its components are to be used by a worker not being directly supervised, you must provide a copy of these instructions and advise the worker that all instructions must be strictly followed. A fall could result in serious injury or death.
- 1.3. Before using any fall arrest system, the worker and employer must become aware of all the requirements of federal, state, provincial and local safety regulations applicable to the use of the fall arrest system and any component thereof. Components of a fall arrest system must be compatible and recommended by Safety Direct or the manufacturer of the device/system.
- 1.4. Never use a fall arrest system or any components for any applications other than specified by the instructions supplied by the manufacturer of that device. Do not alter or adapt the equipment in any way.
- 1.5. Any harness, lanyard, rope grab, self-retracting lifeline or hardware that has been subjected to a fall, must be removed immediately from service. The harness, lanyard, rope grab or hardware must be destroyed and replaced. The SRD must be sent to Safety Direct or authorized dealer for inspection and revalidation.
- 1.6. The combination of the user's weight, clothing and tools may not exceed 310 lbs. (140 kg). If this weight is exceeded the performance and safety of the SRD cannot be guaranteed.
- 1.7. This manual is intended to meet the "Manufacturer's Instructions" as required by CSA Z259.2.2 and ANSI Z359.14 and should be used as part of an employee training program as required by OSHA.
- 1.8. Keep this guide available at all times for easy reference whenever required. Extra copies can be printed from the Safety Direct web site. You can also access it directly using the QR code on the label.

2. YOUR RESPONSIBILITY FOR INSPECTIONS

- 2.1. Carefully take notice of all labels affixed to all components of the fall arrest system. Never use any equipment if the label normally fixed on fall arrest components is obscured or missing.
- 2.2. Every time a fall arrest system is used, check the components of the system before proceeding. They must be complete, compatible and in good working condition.
- 2.3. Careful and regular inspection of the fall arrest system's installation is part of the safety requirements. If you have any questions, contact Safety Direct.

3. YOUR RESPONSIBILITY FOR TRAINING AND SUPERVISION

- 3.1. The state of health of the worker must allow them to withstand a possible fall arrest on the system being used. A worker must not be required to use a fall arrest system if that worker is not:
 - mentally and physically fit for the purpose, especially at heights or in confined spaces;
 - free from the influence of alcohol or drugs;
 - competent for the job to be performed;
 - familiar with the equipment and all applicable safety rules, requirements or regulations;
 - trained for working under the above requirements.
- 3.2. Except for the operations described in this manual, the maintenance of Safety Direct equipment, as well as repair, must be exclusively done by authorized (written approval) Safety Direct dealers or by Safety Direct.
- 3.3. Never let a fall arrest system be managed or used by anyone other than authorized and assigned persons to the job. While out of operation, keep equipment installed or stored out of reach of unauthorized persons.
- 3.4. Prior to putting the systems into operation, rescue procedures should be set up and workers should be trained in the event a fall occurs during a job. Such procedures must be set up by a qualified person or technical consultant according to work conditions.
- 3.5. Every job must be placed under the control of a person having the required qualification and authority for checking that all the instructions prescribed by this manual are regularly and efficiently carried out. Contact Safety Direct for training information.

4. YOUR RESPONSIBILITY FOR COMPONENTS CONNECTED TO THE SRD

- 4.1. Components of the installation other than the SRD must meet the requirements of the applicable regulations and legislation. They must be of the specified quality and must be assembled as a safe and efficient fall arrest system.
- 4.2. Anchor points are to have a minimal strength of 5,000 lbs. (22 kN), be sufficiently strong and in accordance with federal, state, provincial and local regulations.
- 4.3. All requirements in strengths and resistance must be obtained with the necessary safety coefficients.
- 4.4. Prior to commencing the job, all calculations, design and subsequent work necessary to the above requirements must be made by a qualified person on the basis of technical information regarding the site.

5. YOUR RESPONSIBILITY FOR RISK ASSESSMENT

- 5.1. For any job to be performed, consider and control the specific risks related to the nature of the job.
- 5.2. After inspection, should you determine that a fall arrest system, or any component, is no longer to be used, take precautions to remove it so that it cannot be reused. It has to be discarded or disposed of, and precautions must be taken so that it cannot be reused.

6. DESCRIPTION

6.1. The SRD is a portable device supporting the following features:

- Lightweight
- easy to attach as the connector is kept in an upright position
- high strength polymer or aluminum housing has no sharp edges
- web or steel cable
- load indicating swivel snap hook or web telltale

6.2. The function of the SRD is to automatically stop a person's fall. The SRD is primarily intended to connect to a structure while the user is moving vertically directly under the SRD (Figure 1).

The SRD can also be used in other positions as outlined in the section 7.5 on page 8.

A configuration of two SRDs can be used to provide continuous fall protection (100% tie-off) while ascending, descending or moving laterally

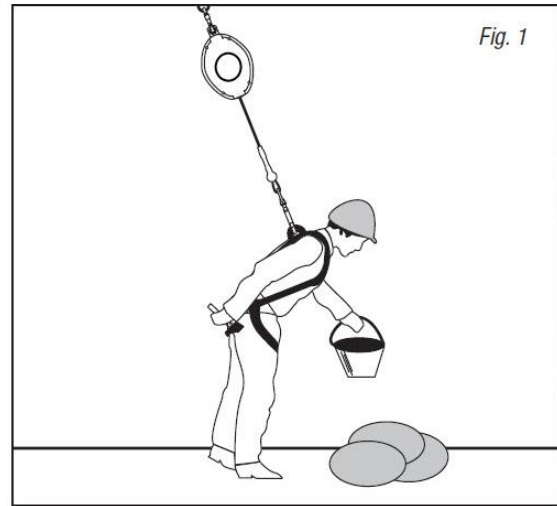

- 6.3. The user is attached to the SRD by a web/cable whose length is automatically adjusted by a retracting spring that activates a drum on which the web/cable is coiled.
- 6.4. In the event of a fall, the drum is locked by brass pawls which engage in a ratchet wheel under the effect of the centrifugal force caused by the acceleration of the falling mass attached to the web/cable. The fall is stopped gradually by the friction of a disk braking system.
- 6.5. Because the web/cable is constantly tensioned between the user and the SRD, the user's free fall distance is held to a minimum by the disk braking system.
- 6.6. Always choose an SRD where the web/cable length fits the expected distance travelled by the user.

7. INSTALLATION ABOVE WORKER

7.1. Anchoring to the structure

- 7.1.1. An anchorage point is a secure point of attachment for lanyards, lifelines or self-retracting lifelines. It has to be independent of the means of supporting the worker and must have been selected by a qualified person. The SRD must be connected to an anchorage point capable of supporting a minimum of 5,000 lbs. (22 kN) per attached worker. Consult governing regulations as revisions occur.
- 7.1.2. Never use an anchorage point that will not allow the carabiner or connecting device to close. The anchor must be compatible with the carabiner or connecting device and must not cause a load to be applied to the gate.

7.2. Connecting to the harness

- 7.2.1. It is mandatory to use a full body harness for fall arrest.
- 7.2.2. Connect components on a safe surface where there is no risk of falling.
- 7.2.3. The point at which the harness is attached must be below the SRD (Figure 2).

7.2.4. The self-locking snap hook fitted on the end of the web/cable must be attached to the back D-ring of the user's harness. It has a visual fall indicator that becomes visible after a fall (Figure 3).

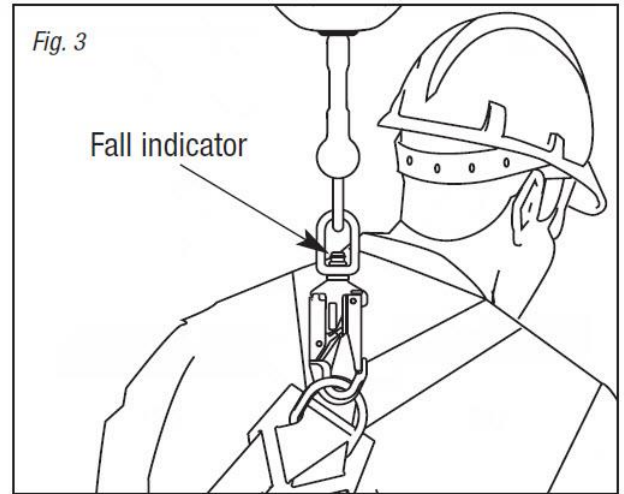
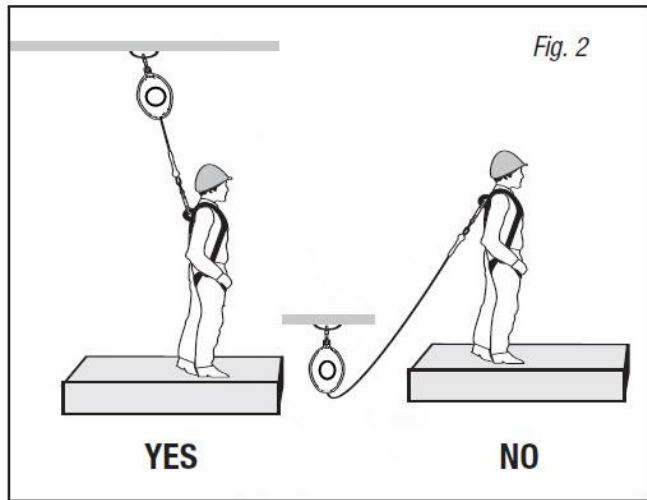

7.3. Clearance

The clearance must be greater than 6 ft. (1.8 m) (Figure 4). When the SRD is installed on a non-rigid anchor point, ensure the deflection of the system is taken into consideration within the calculation of the total clearance required.

7.4. Falls from a kneeling or crouching position will require an additional 1 m (3ft.) of fall clearance.

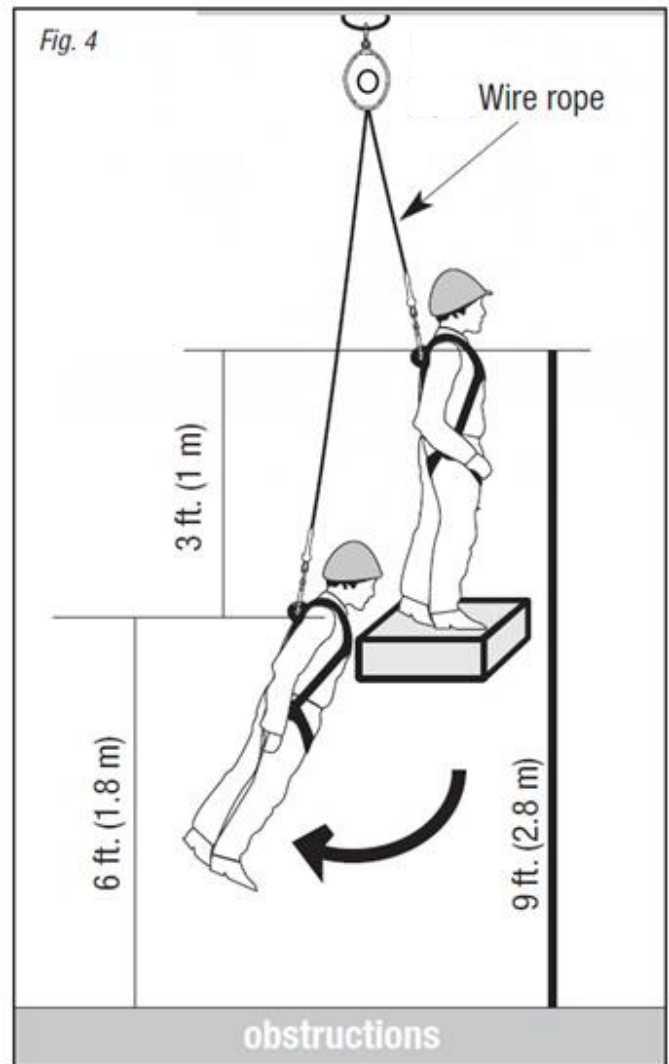

7.5. Assembly Configuration

The most commonly used configuration is where the SRD is attached to a structure and the user moves vertically directly under the SRD.

- 7.5.1. In another configuration, the SRD is suspended from a tripod (Figure 5).
- 7.5.2. If the longitudinal axis of the SRD is at an angle to the vertical, a qualified person must check that all the risks connected with this configuration have been correctly taken into account. Safety Direct recommends that the worker avoid moving away from the vertical plane. In the event of a fall, one will swing from side to side and may hit an obstacle causing injury (Figure 6).

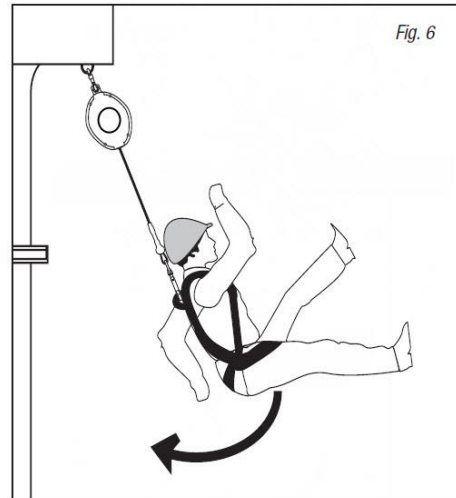
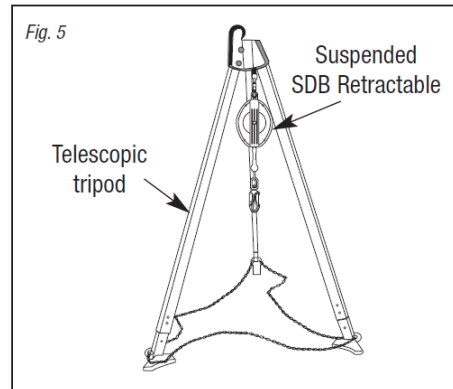

WARNING The user must not exceed an angle of 30° and never move away from the vertical axis of the SRD for more than 10 ft. (3 m) (Figure 7).

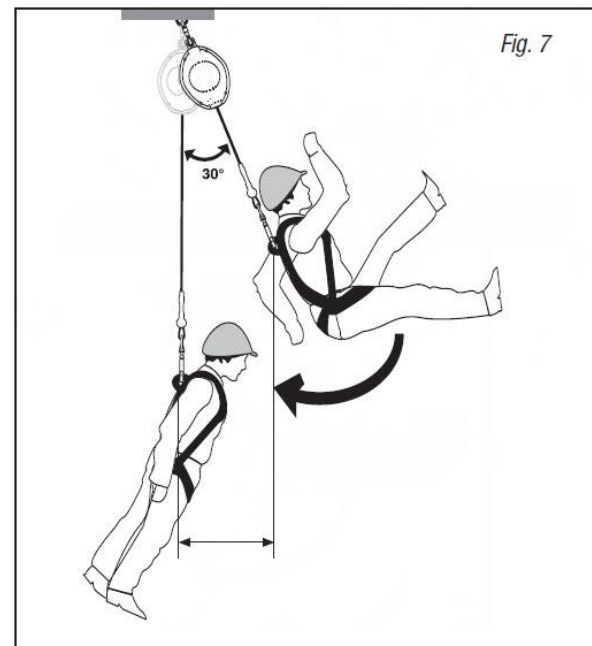

7.5.3. If the user is working on an inclined plane, the risk described in the preceding point does not apply. The fall distance will depend on the slope, condition of the surface, etc. (Figure 8).

WARNING Care should be taken to avoid contact with all sharp edges which could cut the web/cable.

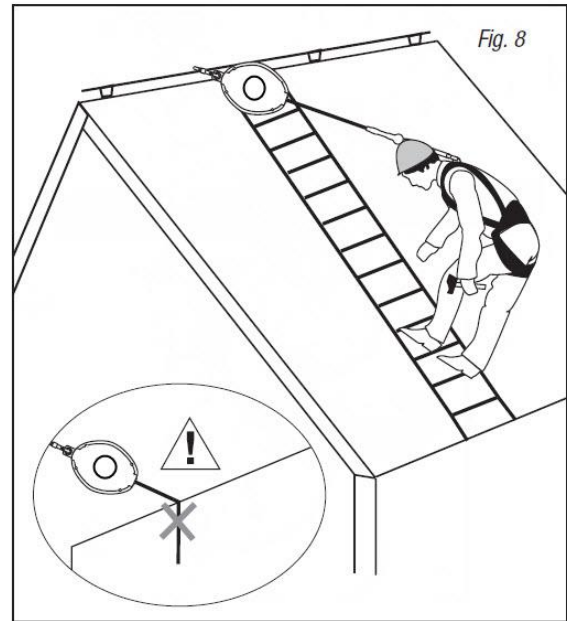

WARNING For all assembly configurations: The anchoring to the structure must allow self-alignment of the SRD under the effect of the force exerted on the web/cable. Mount the SRD with the carabiner inserted through the built-in swivel at the top of the unit.

(Figure 10).

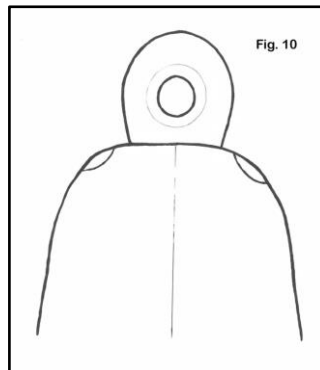

8. INSTALLATION ON HARNESS

8.1. Loosen the harness webbing by pulling on the web straps (A) where they pass through the bottom of the dorsal D-Ring (B) until there is some space between the web straps and the back pad.

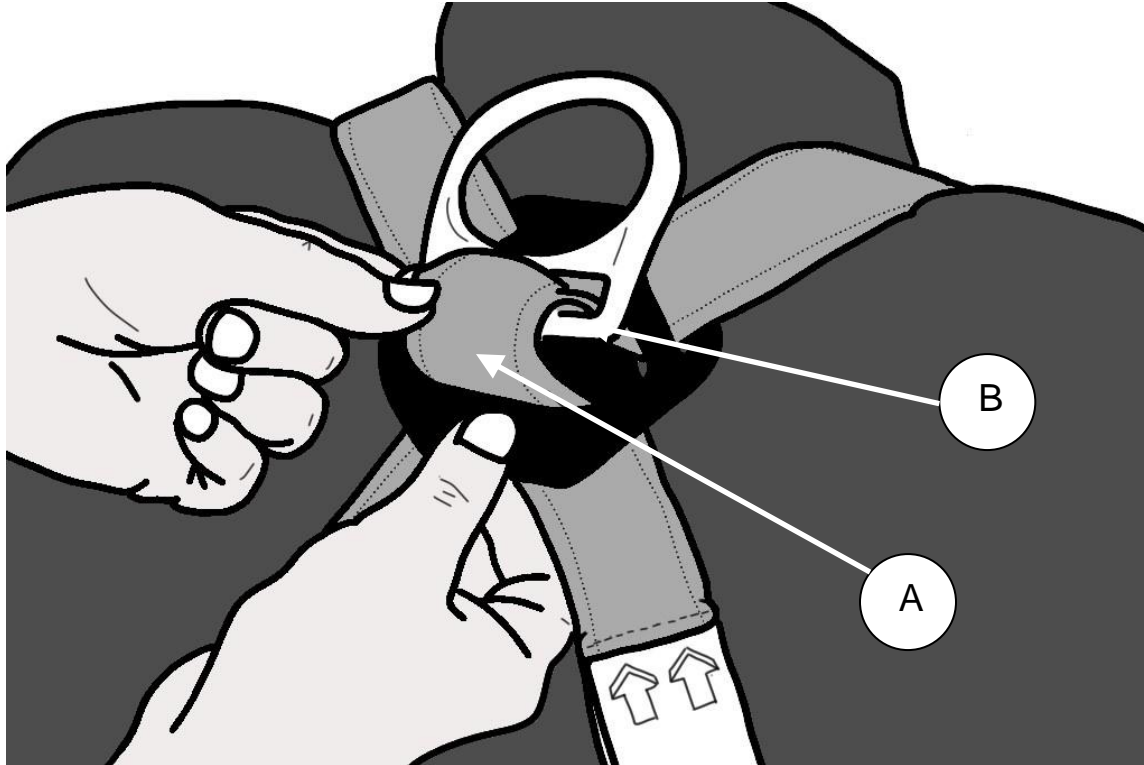

8.2. Hold the connector with the locking bar (C) at the bottom.

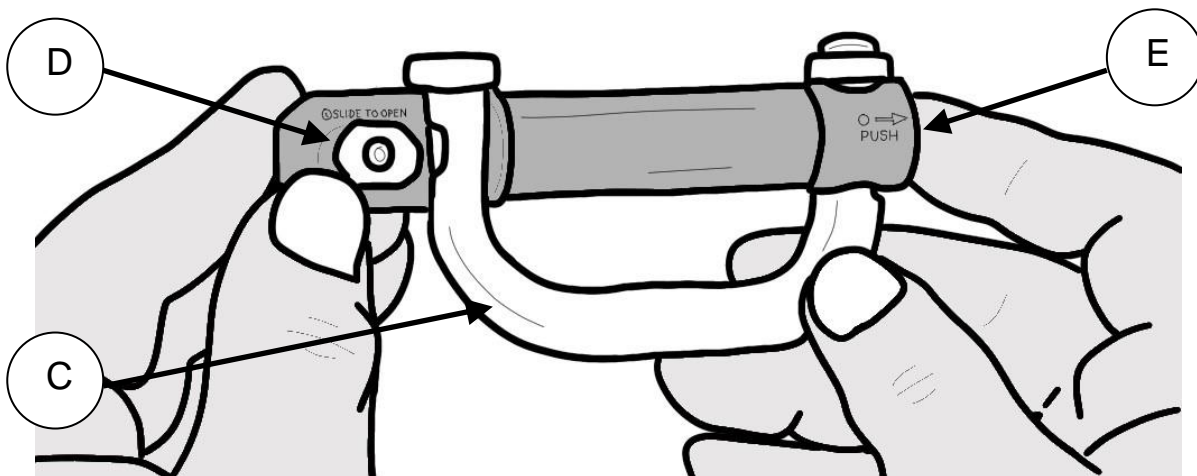

8.3. Slide the locking button (D) to the left and hold it to unlock the bar

8.4. Press the release button (E) inward until you hear a click. Then pivot the bar towards you.

8.5. Insert the barrel of the connector (F) into the space between the webbing and back pad.

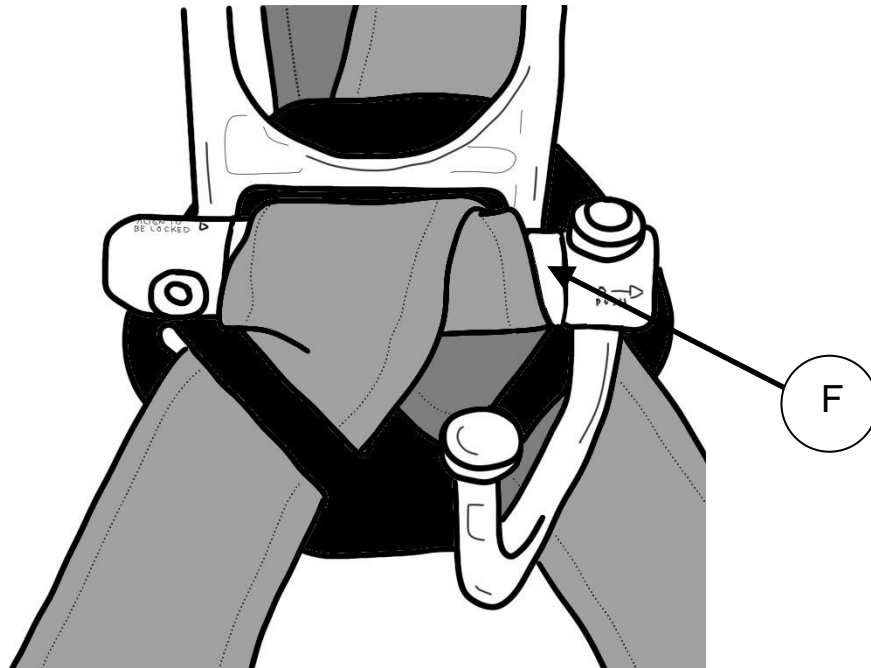

8.6. Attach the SRD's to the connector by inserting the locking bar (G) through the swivel eyes (H) on the top of each SRD

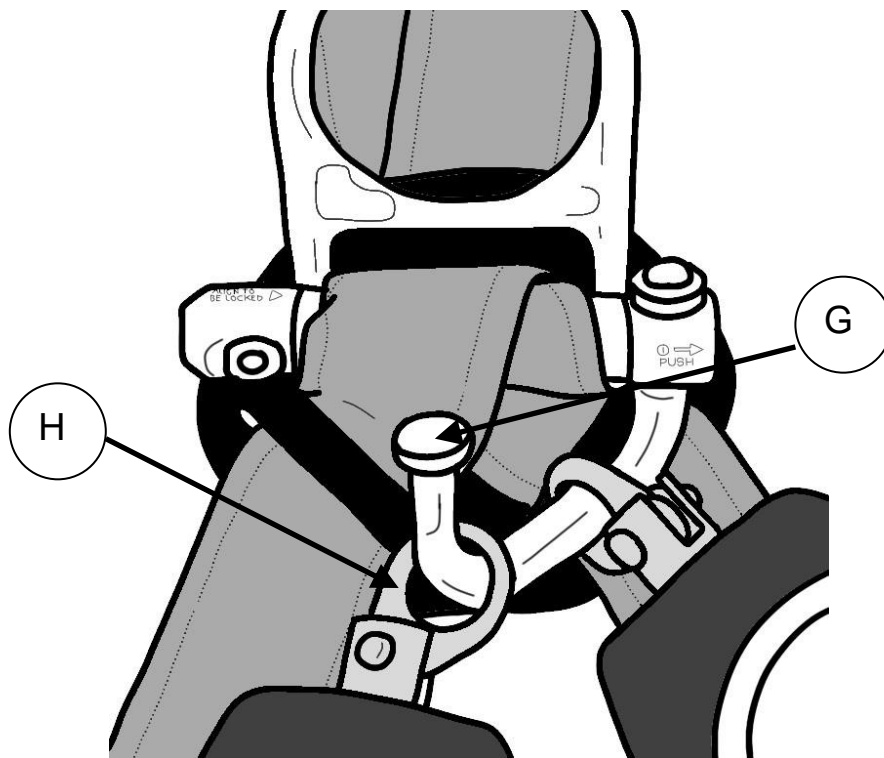

8.7. Close the connector by moving the webbing away from the slot and pushing on the locking bar until it clicks. The indicator will be RED if the carabiner is not locked properly.

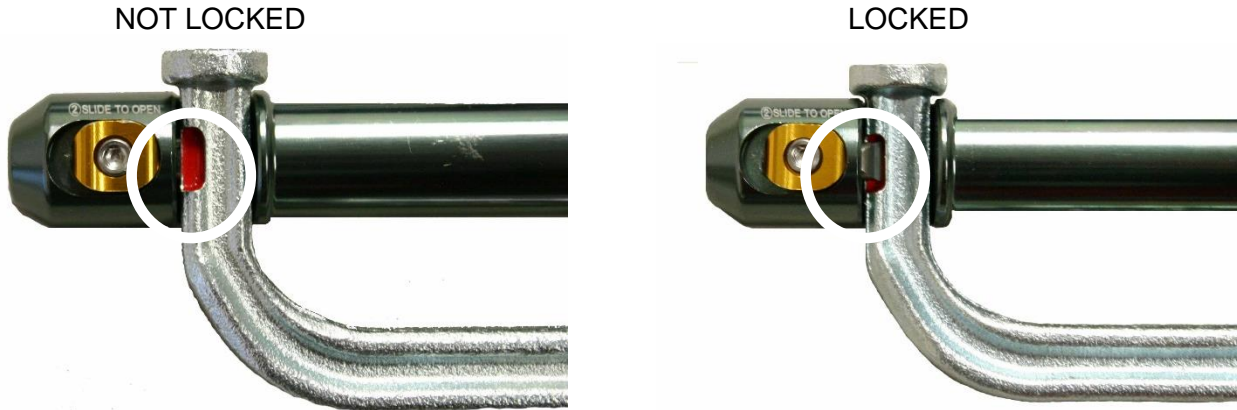

8.8. Adjust the harness by pulling the web straps (I) back through the dorsal D-Ring to remove the slack from the webbing

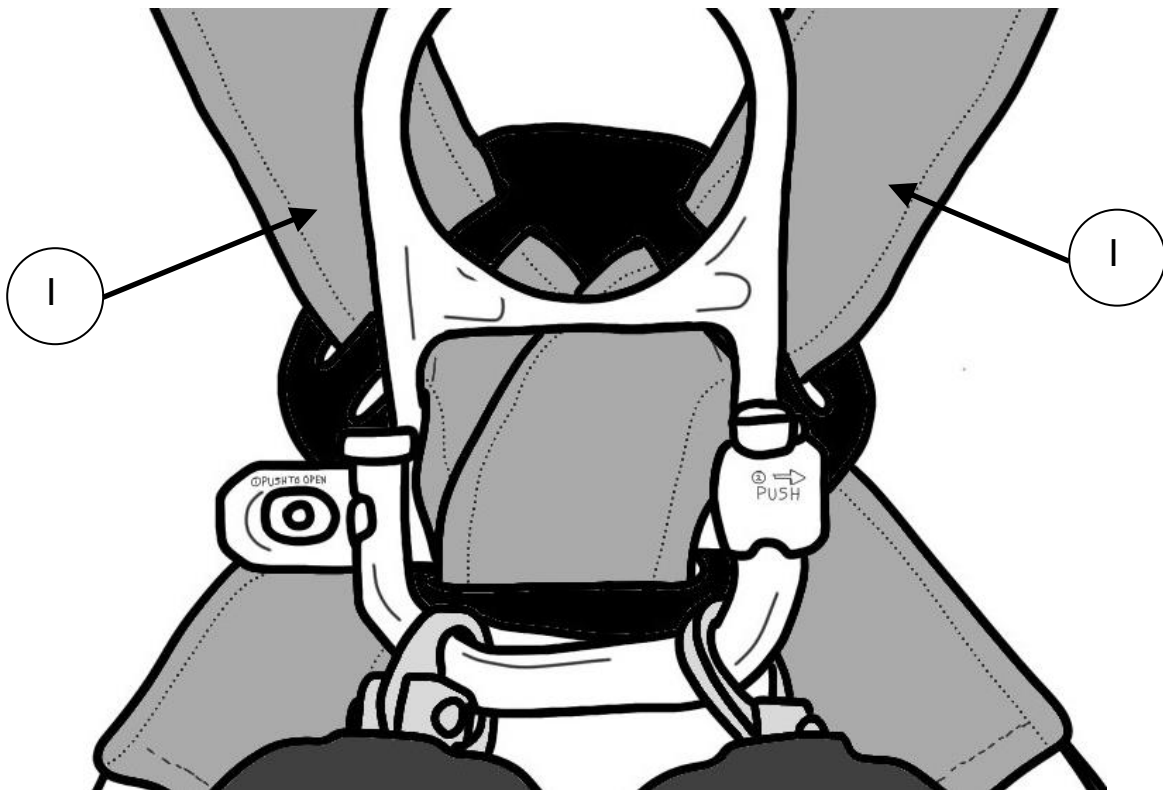

9. OPERATION

9.1. SINGLE UNIT

The user connects the self-locking swivel eye snap hook to the harness dorsal D-ring and moves at a speed of less than 6.6 ft./sec. (2 m/sec.), which corresponds to normal walking speed.

DUAL UNIT

The user connects one leg to an anchorage point, moves to a new location, attaches the second leg to another anchorage point, then disconnects the first leg.

- 9.2. The web/cable unwinds, exerting a light pull on the user. If any slack appears in the web/cable, replace the device immediately.
- 9.3. If there are sudden jerks on the line, the SRD may lock. The user must then move smoothly towards the SRD to unlock it. If the device keeps locking when it should not, replace it.
- 9.4. In the event of a fall, the SRD stops the fall automatically. The user must then be rescued as quickly as possible, within 15 minutes at most.
- 9.5. Once the user has unhooked from the web/cable, they should hold the end and allow the line to wind back onto the reel. Do not let it freely retract without holding the line. If necessary, use a small tagline when operating retractable lifelines that are positioned out of reach.
- 9.6. Locking Speed:
Situations which do not allow for an unobstructed fall path should be avoided. Working in confined or cramped spaces may not allow the body to reach sufficient speed to cause the SRD to lock if a fall occurs. Working on slowly shifting material, such as sand or grain, may not allow enough speed buildup to cause the SRD to lock. A clear path is required to assure positive locking of the SRD

*WARNING Do not let go of the web/cable
until it has completely rewound inside the SRD.*

10. ENVIRONMENT

- 10.1. The SRD can be used in the following operating environments
- conditions generally found on an outdoor building site;
 - in temperatures ranging from -31° F (-35° C) to 176° F (80° C);
 - work that involves spraying products (sandblasting, painting, etc). It is advisable to protect the SRD against contaminants entering the housing.
- 10.2. Electrical hazards
Take extreme caution when working near or around high voltage power lines: electricity could pass through the SRD or connecting devices resulting in electrocution.

11. RESCUE

- 11.1. A study should be done to define how (in terms of personnel and equipment) an injured person is to be rescued. The rescue should take no more than 15 minutes. Any longer may endanger the safety and health of the person being rescued. After rescue, remove the SRD from use.
- 11.2. During a rescue, the line or lines should be attached only to the dorsal D-ring and/or to both shoulder mounted D-rings of the harness if so equipped.

12. LIMITATION OF THE EQUIPMENT

The limit of one person per SRD and personal fall arrest system must always be observed.

- 12.1. Capacity
The SRD has a 310 lbs. (140 kg) rated working capacity. User's weight including clothing and tools may not exceed 310 lbs. (140 kg).
- 12.2. Electrical hazards
Take extreme caution when working near or around high voltage power lines: electricity could pass through the SRD or connecting devices resulting in electrocution.
- 12.3. Explosive atmosphere and chemical products
All internal metal parts are non-sparking. In general, the unit will not be affected by chemicals (acids or bases). For very aggressive environments, consult Safety Direct.
- 12.4. Temperature
Do not use the SRD in places where ambient temperature are lower than -31° F (-35° C) and higher than 176° F (80° C).
- 12.5. Impact
Any SRD subjected to arresting a fall shall be removed immediately from service. It must be inspected and revalidated by a qualified person from Safety Direct or by a dealer authorized by Safety Direct to carry out such service.
- 12.6. Moving machinery
Exercise extreme caution when working near or around moving machinery.
- 12.7. Sharp edges/abrasive surfaces
Keep the lifeline away from sharp edges or abrasive surfaces. If this cannot be totally avoided, protect the web/cable of the SRD accordingly.
- 12.8. Life
Every SRD that shows signs of wear, damage or degradation must be removed from service and sent back to Safety Direct or its authorized dealer in order to be inspected and revalidated by a qualified person.

13. INSPECTION

- 13.1. All equipment must be inspected visually before each use and periodically by a qualified person. If damage is found as described below, immediately remove the item from service and replace it. If any damage or questionable conditions are apparent that are not described below, immediately remove the item from service, replace it and contact Safety Direct Ltd for advice.
- 13.2. Failure to remove equipment from service that has been damaged or is in questionable condition could lead to serious or fatal injury. A detailed record of inspections should be maintained with the date, inspectors name and signature, the pass or fail status, and corrective action for failed items.
- 13.3. Service Start Date
Canadian Standards Association (CSA) requires inspection, maintenance and revalidation based on type of usage (see 10.9 Inspection Table). Before operating the SRD, read the In Service Date on the label. If the recommended time limit has passed, do not use the SRD and send it back to Safety Direct or to an authorized dealer.

13.4. Cable

Extend the complete length of the cable and examine it in order to spot damage.

Cable should be free of birdcage or loop formations, it must not be crushed, kink, cut, torn from sharp edges, etc. (Figure 11).

It should also be free of any loose materials such as dirt, sand, petroleum, chemical contaminants or any other foreign matter.

A change in the original diameter of the cable is an indicator of a weakened area from extreme load.

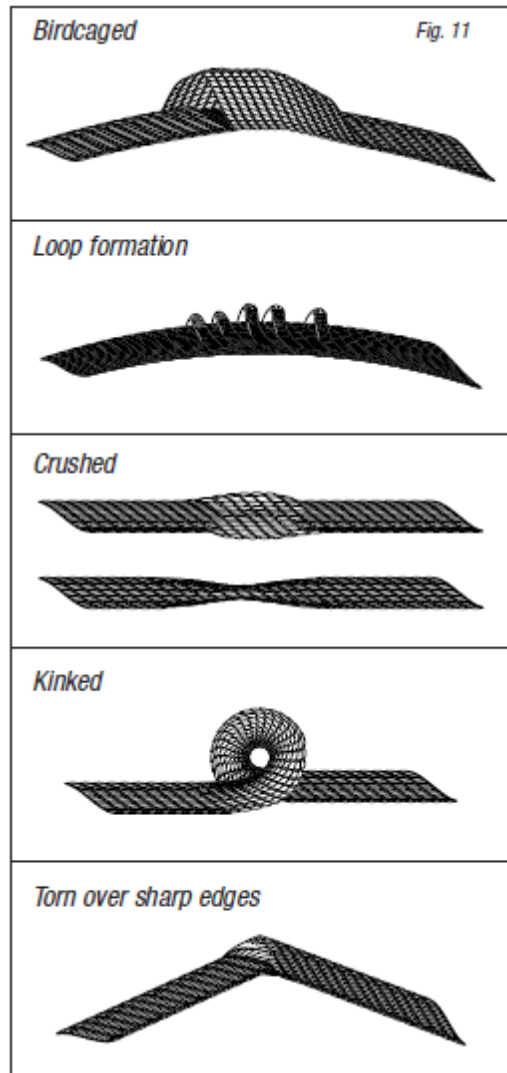

13.5. Webbing

Extend the complete length of the webbing and examine it carefully to spot damage.

Webbing should be free of frayed edges, burns or cuts.

It should also be free of any loose materials such as dirt, sand, petroleum, chemical contaminants, or any other foreign matter.

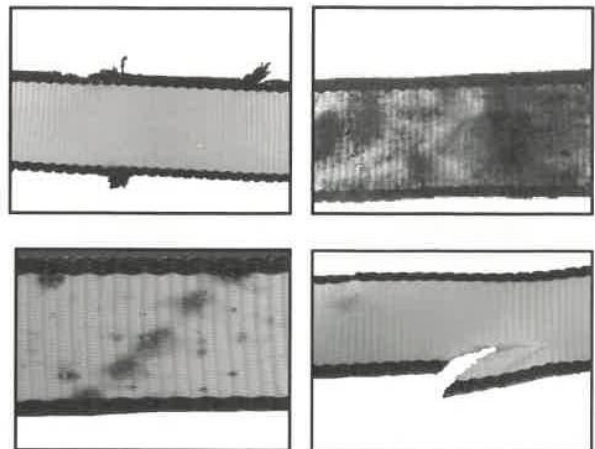

13.6. Self Retracting Device

Pull the end of the web/cable sharply in order to make sure it locks. The SRD will stop the retraction of the web/cable as soon as the activation speed is reached. All equipment that shows any sign of distortion or corrosion must be immediately removed from service.

WARNING Bolts or rivets that are discolored, pitted or cracked indicate chemical corrosion. All equipment where the housing has marks of impact or distortion must be removed from service and sent back to Safety Direct Ltd or to an authorized dealer.

13.7. Load Indicating Swivel Snap Hook

The self-locking snap hook is specially designed so that should a fall occur, the indicator will activate, causing the swivel axle to drop and create a gap between the swivel component and the hook body (Figure 12).

Always ensure that the indicator has not been activated before using the SRD. All parts of the self-locking snap hook should be free of distortion. The gate should be seated into the nose without binding and should not be distorted or obstructed. The gate spring should exert enough force to firmly close the gate. The gate lock must prevent the gate from opening when closed.

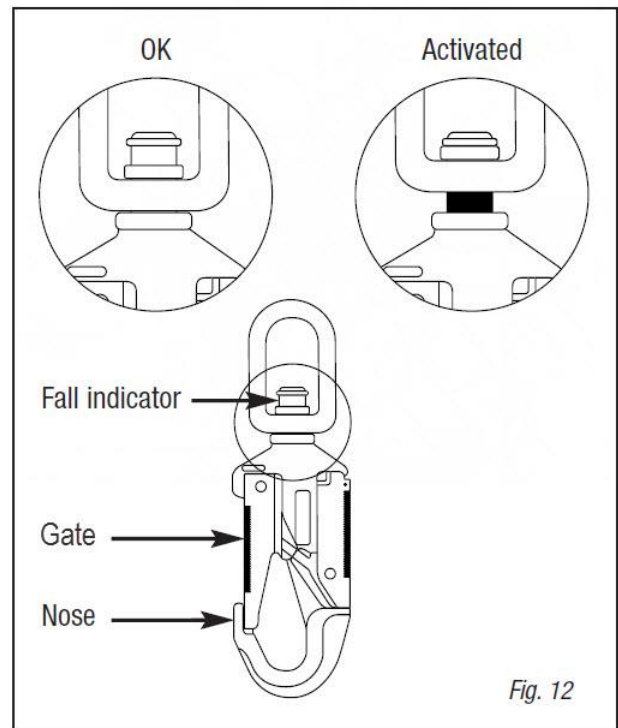

13.8. Load indicator on webbing

Always ensure that the indicator has not been deployed before using the SRD. There should be no broken stitching.

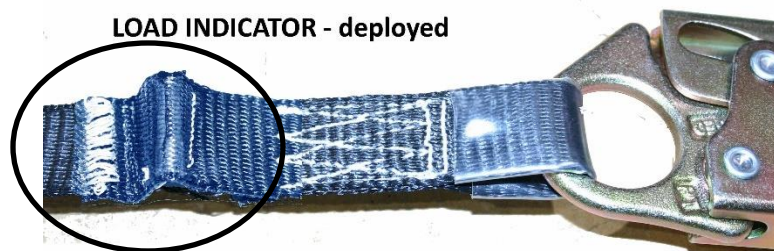
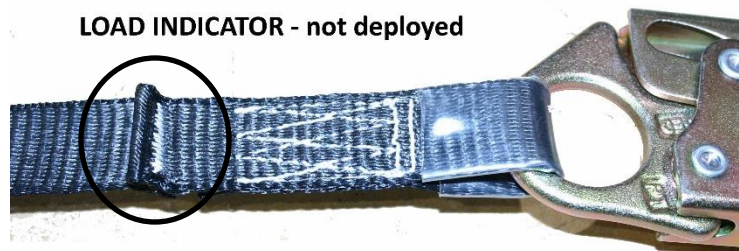

13.9. Anchorage connector

All parts of the carabiner should be free of distortion. The gate spring should exert enough force to firmly close the gate. Special attention must be paid to the mechanism, which should close adequately. The safety bar of the auto-locking carabiner must complete its rotation when closed.

13.10. Other components

Refer to appropriate inspection instructions.

WARNING: Any equipment that fails to meet the above inspection requirements shall be removed from service. Only Safety Direct or persons or legal entities authorized in writing by Safety Direct, shall make repairs to Safety Direct fall arrest equipment.

13.11. Inspection Table

Type of Use	Infrequent to Light	Moderate to Heavy	Severe
Application	Rescue Confined spaces Factory maintenance	Residential construction Transportation Utilities Warehouse	Commercial construction Oil and Gas Mining Foundry
Storage conditions	Good	Fair	Harsh
Environment	Clean Room temperature	Clean or Dusty All temperatures	Dirty All Temperatures
Inspection by the worker	Before each use	Before each use	Before each use
Inspection by a competent person	Annually	Semi-annually to annually	Quarterly to semi-annually
Revalidation frequency	At least every 5 years	At least every 2 years	At least every year

13.12. Failure of a worker to perform “before each use” inspection or failure of an inspection by a worker shall initiate the requirement for inspection by a competent person.

13.13. Failure of a competent person to perform inspections as specified in this table, or failure of an inspection by the competent person shall initiate product revalidation or disposal.

13.14. Determination of the type of use category shall be determined by a competent person.

13.15. An SRD that is considered non-repairable, or not designed for disassembly where internal inspection is not possible without rendering it unserviceable, does not require revalidation during the serviceable life of the unit. Before use and annual inspections are still required for proper operation

13.16. Inspection Frequency

The product shall be inspected by the user before each use and, additionally, by a Competent Person other than the user at intervals of no longer than one year. A higher frequency of equipment usage and harsher conditions may require increasing the frequency of Competent Person inspections. The frequency of these inspections should be determined by the Competent Person per the specific conditions of the worksite.

13.17. Product Life:

The functional life of the product is determined by work conditions and maintenance. Providing the product passes inspection criteria, it may remain in service.

14. LABELLING

14.1. Read all the labels on the SRD. They must always be intact and legible.

14.2. Front and back labels contain:

- Manufacturer's name
- Product type
- Model number
- Working length
- Materials
- Maximum arresting force
- Maximum arresting distance
- CSA/ANSI/OSHA standards
- Date the device went into service
- QR code for these instructions



14.3. Side labels contain:

- Warnings

14.4. The housing is stamped with

- Serial number
- Date of manufacture



WARNING

Follow all manufacturer's instructions included at time of shipping
This device shall be removed from service when the visual load indicator is deployed
Lifeline shall not contact edges or surfaces during fall arrest
Anchor above user's Dorsal D-Ring

ADVERTISSEMENT

Suivre toutes les instructions du fabricant fournies avec le dispositif lors de sa livraison
Ce dispositif doit être retiré du service lorsque l'indicateur de chute de l'utilisateur est actif
La corde d'assurance ne doit pas entrer en contact avec des bords ou des surfaces lors de l'attache de chute
Ancrer au-dessus de l'anneau en D dorsal du harnais de l'utilisateur

15.TROUBLESHOOTING

15.1. Rewinding problem

If the web/cable does not rewind correctly into the housing, pull it until fully extended and examine its condition (see section 10.4). Let it rewind by itself while under tension, do not let go. If the problem remains, this could indicate that the inside spring may be clogged or corroded, or that the housing may have been distorted. In that case, do not use the SRD and send it back to Safety Direct or to an authorized dealer for servicing by a qualified person.

If a section of the web/cable does not rewind in the SRD, check the indicator on the swivel eye snap hook or the telltale indicator sewn in the webbing next to the snap hook; it may have been involved in stopping a fall. The SRD must be immediately removed from service and returned back to Safety Direct or to an authorized dealer for servicing.

15.2. Unwinding problem

If the web/cable does not unwind normally or if it moves along in jerks, pull out the complete length by hand and examine its condition (see section 10.4). Let the line retract without letting it go. If the problem has not disappeared, send the SRD back to Safety Direct or to an authorized dealer for servicing.

15.3. Jammed SRD

If the web/cable does not move at all, do not use the SRD. Send it back to Safety Direct or to an authorized dealer for servicing.

16.MAINTENANCE AND STORAGE

16.1. Failure to maintain and store equipment carefully can result in damage and malfunction that could lead to a serious or fatal injury. The good condition of the web/cable and of the SRD is critical for safe use.

16.2. Maintenance and cleaning

CABLE Unwind the complete length, clean and lubricate it with a cloth lightly soaked in oil.
WEB Unwind the complete length and clean both sides with a damp cloth
Let it rewind slowly and do not let go of the end until it is fully retracted into the housing.
Clean the housing of the SRD with a damp cloth.

WARNING: Do not use products such as solvents on the SRD.

16.3. Storage

When the SRD is not in use, it must be kept in a dry environment and sheltered from weather. When stored, the web/cable must be totally coiled within the SRD housing.

17.WARRANTY INFORMATION

WARNING: Under no condition whatsoever, no other person, means or legal entity is ever allowed to replace the swivel snap hook other than Safety Direct or authorized dealer.

17.1. Safety Direct warrants its equipment to be free from defects in material and workmanship under normal use and service.

17.2. Safety Directs obligation under this warranty is limited to repairing or replacing, at our option, any part of the unit, which proves under examination to our satisfaction, to be defective in material or workmanship. The item in question is to be returned to Safety Direct upon authorization of the distributor,

transportation prepaid, within twelve (12) months from the date the equipment was sold to the original purchaser. Return shipment must be prepaid.

- 17.3. Any parts proven to be defective upon inspection by Safety Direct will be repaired or replaced at no cost.
- 17.4. The obligation under this warranty does not include labour or transportation costs or ensuing damages of any kind.
- 17.5. Any defect in this equipment must immediately be brought to the attention of Safety Direct. The distributor will make arrangements with the factory for repairs or replacements of the parts within the terms of this warranty.
- 17.6. Safety Direct's obligation is restricted to replacing parts and does not include the complete unit. The warranty is void on any unit that has been modified or tampered with; repaired by persons other than a factory representative or an authorized Safety Direct distributor; repaired with other than Safety Direct standard parts; or damaged by reasons of accident, alteration, misuse or abuse.
- 17.7. This warranty is in lieu of all other warranties, expressed or implied. We do not authorize any person or representative to make any other guarantee or to assume for us any liability in connection with the sale of our appliances other than those contained herein. Any agreement outside of or contradictory to the foregoing shall be void and of no effect.

This booklet is neither a regulations compliance guide nor a general training guide for fall arrest systems. You must refer to instructions delivered by manufacturers of the pieces of equipment included in your system. Whenever calculations and specific installations are required, the worker should be professionally trained to that end and should secure relevant information prior to commencing such work.

Safety Direct Ltd. reserves the right to modify the specifications of the equipment described in this manual.