



Pro Series Safety Winch

Operator's Manual



Man-Rated for:

Work Positioning

Confined Space Entry / Retrieval

Rescue

Fall Protection

Also Rated for Material Handling Applications



Table of Contents

1. WARRANTY INFORMATION
2. INTRODUCTION to WINCH APPLICATIONS
3. APPLICATION RESTRICTIONS
4. GENERAL SYSTEM REQUIREMENTS
5. WINCH INSTALLATION and OPERATION
6. TRAINING
7. INSPECTION
8. MAINTENANCE LUBRICATION and STORAGE
9. SPECIFICATIONS



FIVE STAR LIMITED WARRANTY (Safety Equipment)

(Canada & U.S.A. Only)

Tuff Built Products Inc. hereinafter named the "Company" warrants, in accordance with the provisions below, to each user/purchaser of new Tuff Built Products equipment from an authorized Tuff Built Products Dealer or the "Company", that such equipment is free from defects in material and workmanship and will be warranted for a period of up to 120 months from date of sale or lease to the first user/purchaser, if used and serviced in accordance with the recommendations in the Operator's Manual. Replacement is at the discretion of the "Company".

The obligation of the "Company" under this FIVE STAR limited warranty is limited to repairing, or at its option, replacing any part(s), which, in the "Company's" judgment, is defective.

Except as set forth above, THE "COMPANY" SHALL HAVE NO OBLIGATION OR LIABILITY OF ANY KIND ON ACCOUNT OF ANY OF ITS EQUIPMENT, AND SHALL NOT BE LIABLE FOR SPECIAL OR CONSEQUENTIAL DAMAGES. THE "COMPANY" MAKES NO OTHER WARRANTY, EXPRESS OR IMPLIED, AND SPECIFICALLY, THE "COMPANY" DISCLAIMS ANY IMPLIED WARRANTY OF MERCHANTABILITY OR FITNESS.

The specific details of the Owner's FIVE STAR Limited Warranty, outlined in more detail in "Limited Warranty Detail" attached to this certificate, are expressive of the quality built into your equipment.



Limited Warranty Detail

FIVE STAR LIMITED WARRANTY DETERMINATION

Only defective parts are covered by this FIVE STAR limited warranty. Any part or parts of a "Company" product found to be defective for a period of up to 120 months from date of sale or lease to the first user/purchaser, in accordance with the provisions of this FIVE STAR limited warranty, will be repaired or replaced by a "Company" authorized technician at the discretion of the "Company".

ITEMS COVERED BY FIVE STAR LIMITED WARRANTY

The Tuff Built Products FIVE STAR limited warranty includes the replacement or repair of any part on the "Company's" new equipment purchased from an authorized Tuff Built Products Dealer or the "Company", which are defective in material, workmanship, or both (as determined by an authorized representative of the "Company").

This FIVE STAR limited warranty is only valid if the scheduled maintenance is performed as outlined in the Operator's Manual by a "Competent Person" and a signed log evidencing the work performed is maintained and provided to the "Company" upon request. A "Competent Person" is a representative of the user/purchaser who has been trained on the proper use and maintenance of purchased Tuff Built equipment by a factory authorized trainer. A factory authorized trainer may be a representative of the Company or other such person who has been certified by the Company.

Genuine Tuff Built Products replacement parts will be warranted for 90 days from date of purchase, or the remainder of the original equipment limited warranty period, whichever is longer.

OBTAINING FIVE STAR LIMITED WARRANTY SERVICE

To obtain FIVE STAR limited warranty service, contact the "Company". Provide a written description of the issue and provide copies of the most recent completed scheduled maintenance logs. Such logs must be completed by a Competent Person.



FIVE STAR LIMITED WARRANTY EXCEPTIONS

1. MODIFIED OR ALTERED EQUIPMENT - No warranty shall apply on any equipment or parts that have been modified, or altered in any way without prior approval and knowledge of the "Company". Nor is there warranty if service, other than normal replacement of service items, is performed by someone other than a "Company" authorized technician.
2. NORMAL WEAR OR MAINTENANCE PARTS – Tuff Built Products Inc. shall not be responsible for normal replacement parts under the provisions of this FIVE STAR limited warranty. **Consult your Operators Manual to obtain a list of affected parts and service coverage.**
3. MISCELLANEOUS - No warranty shall apply to damage resulting for accident, misapplication, abuse, or damage caused by environment (such as exposure to corrosive material).

ABOUT IMPROVEMENTS

Tuff Built Products Inc. is continually striving to improve its products, and therefore reserves the right to make improvements or changes when it becomes practical and possible to do so, without incurring any obligations to make changes or additions to the equipment sold previously.



HOW TO ACTIVATE AND MAINTAIN THIS FIVE STAR LIMITED WARRANTY

1. Complete and return the Limited Warranty Registration Form to the "Company"
2. Scheduled maintenance may be performed by a representative of the "Company", a "Company" authorized Dealer, or by the user as authorized by the "Company" (with valid certification). Determine how you wish scheduled maintenance to be performed and so advise the "Company". If scheduled maintenance is performed by the user the person(s) involved must be authorized by the "Company" and training may be required.
3. Establish the scheduled maintenance log as outlined in the Operator's Manual and *perform scheduled maintenance*. The original is to be maintained by the user and available to a "Company" authorized technician when required.
4. **IMPORTANT.** *The purpose of this procedure is to ensure that equipment manufactured by Tuff Built Products Inc. is, to the best ability of the "Company", available when needed to perform its function, that is save lives. Failure to follow this procedure increases the hazard that this equipment will not be available when needed and will void the warranty.*



WARRANTY REGISTRATION

IMPORTANT. This Warranty Registration Form must be completed and returned to Tuff Built Products Inc. in order to activate your FIVE STAR limited warranty. Retain a copy for your records

Your FIVE STAR Limited Warranty (120 months) will be activated when receipt of this Warranty Registration Form is confirmed by Tuff Built Products Inc. It is the Owner's responsibility to establish a maintenance schedule according to the Owner's manual and properly record it.

Organization/Department: _____

Address 1: _____

Address 2: _____ E-mail: _____

Town/City: _____ Postal Code: _____

Province/State: _____ Tel: _____

Country: _____ Fax: _____

Contact: _____ E-mail: _____

Model #: _____ Dealer _____

Serial #: _____ Dealer Phone #: _____

Date Received: _____ Salesman: _____

<i>Confirmation (for Tuff Built use only)</i>	
<i>Date Received:</i>	_____
<i>Registration #</i>	_____
<i>Signature & Title</i>	_____

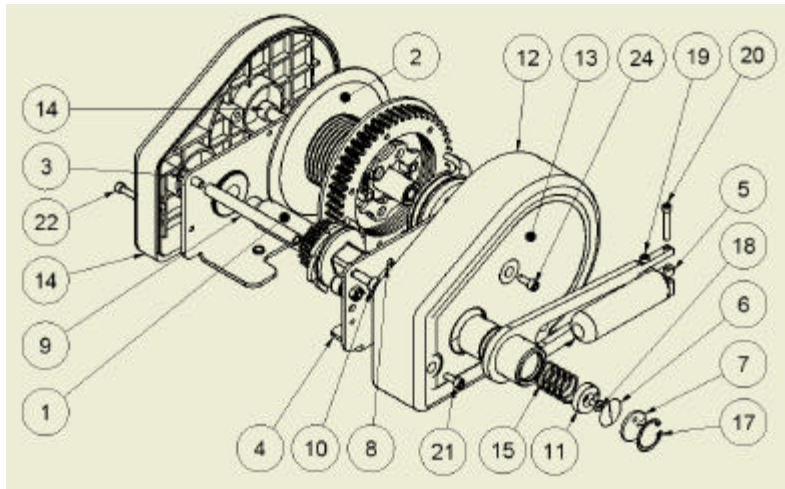

Item Number	Description
1	Pinion Shaft Assembly
2	Drum Spool Assembly
3	LHS Side Plate Assembly
4	RHS Side Plate Assembly
5	Crank Handle Knob Assembly
6	Brake Wear Indicator Label
7	Brake Wear Indicator Window
8	
9	Rear Frame Spacer
10	Rear Frame Spacer Screw
11	Crank Handle Spring Retainer Disc
12	RHS Cover
13	RHS Cover Label
14	LHS Cover
15	Crank Handle Spring
16	
17	Brake Wear Indicator Window Retainer Clip
18	Crank Handle Spring Retainer Disc Mounting Screw
19	Crank Handle Knob Assembly Mounting Screw
20	Crank Handle Knob Assembly Retaining Screw
21	Long RHS Cover Mounting Screw
22	LHS Cover Mounting Screw
23	
24	Short RHS Cover Mounting Screw

Figure 1, Winch Parts and Location

Note:

For purposes of honoring warranty claims, wear to brake pads, cable retainer spring bar, labels, and winch lines are considered part of normal winch operation and are not covered by the warranty.



2. INTRODUCTION to WINCH APPLICATIONS

Congratulations on your purchase of a Best Safety Systems Pro-Series Man-Rated Winch as part of your safety at heights equipment.

Pro-Series winches combine many advanced safety features, including multiple brake pawls, a secondary inertia actuated brake, easy to read visual brake wear indicator, visual overload indicator integral to the snap hook, and optional usage indicator.

The winch may be equipped with a variety of winch line options including, stainless or galvanized steel cable in various diameters, and ropes in various diameters and constructions to meet your specific job requirements.

This product has been specifically designed and carefully manufactured to provide reliable operation in many different safety-at-heights applications. These include, but are not limited to:

2.1 WORK POSITIONING

The winch may be used for the suspension of a worker at a work position for the performance of a task. When a worker is suspended in a work seat or harness, a secondary personal fall arrest system must be used in addition to the suspension line. Personal fall arrest systems used with this winch must meet applicable OSHA or other local requirements.

NOTE: OSHA 29 CFR 1926 Subpart L considers this application to be a single point suspension scaffold, and requires treatment as such.

2.2 RESCUE

The winch may be used as part of a system to allow for the post-fall rescue of a worker protected by a personal fall arrest system. This winch meets the requirements of ANSI/ASSE Z359.4 for use as a rescue device.

2.3 CONFINED SPACE ENTRY / RETRIEVAL and RESCUE

The winch may be used as part of a system to facilitate access to and egress from a confined space as well as non-entry rescue in the event of an emergency. This winch meets the requirements of OSHA 1910.146, and ANSI/ASSE Z117.1 for use as a confined space entry/retrieval and rescue device.

2.4 FALL PROTECTION WHILE CLIMBING

In situations where it is not practical to install and use a temporary or permanently installed personal fall arrest system, the winch may be used to guard against falling while climbing a fixed ladder or other structure. The winch line can be used as essentially a travelling anchorage connector that moves up and down with the climber. An energy absorbing lanyard is installed between the winch line and the dorsal D-ring on the climber's full body harness. The winch must be operated so as to continuously eliminate any slack in the winch line as the climber moves up and down. The winch operator must be specifically instructed in such use of this winch. All installations must be designed, installed, and used under the supervision of a qualified person.

2.5 MATERIAL HANDLING

The winch may be used for the raising and lowering of tools, equipment, and other material not exceeding the rated Working Load Limit of the winch. Various jurisdictions may not allow the use of the same equipment to move personnel and material. Be aware of and follow the regulations governing your workplace.

3. APPLICATION RESTRICTIONS

There are restrictions and limitations that must be carefully considered in the selection, installation, and operation of this winch. Serious injury or death may result from failure to consider these factors.

3.1 WORKING LOAD LIMIT

This winch is designed and rated to a working load limit of 1 person weighing a maximum of 310lbs (including all clothing, tools, and equipment) when used in a 1 Part Single Reeved System, or 2 persons weighing a maximum 620 lbs when used in a 2 Part Single Reeved System (see Figure 2).

1 Part single reeved system

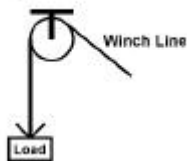

2 Part single reeved system

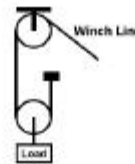

Figure 2, 1 & 2 Part Single Reeved Systems

Please refer to the Operator's Manual(s) for all other accessories in the system to determine which reeving option(s) are applicable to the system.

Note: Please be aware that a 2 Part Single Reeved System is rated for a higher working load limit, but that raising/lowering speed is only half that of a 1 Part Single Reeved System.

Ensure that all other system components have a working load limit matching that of the winch. System rating is equal to that of the lowest rated system component.

3.2 SITE CHARACTERISTICS, PHYSICAL and ENVIRONMENTAL FACTORS

Work sites have associated with them any of a number of hazards related to the site itself. These may include, but are not limited to poisonous or explosive atmospheric conditions, poisonous or corrosive chemical hazards, hot surfaces, electrical hazards, sharp edges, engulfment hazards, or moving machinery.

All of these factors must be taken into consideration when selecting equipment for a given application.

4. GENERAL SYSTEM REQUIREMENTS

This winch is designed for use with a variety of accessories to perform many functions. There are requirements common to all such systems that include, but are not limited to, the following.

4.1 ANCHORAGE STRENGTH

This winch is designed to be used in conjunction with a supporting structure capable of providing the required anchorage strength. Supporting structures designed, manufactured, and/or approved by Tuff Built Products Inc. will have sufficient strength for the approved application. Any supporting structure not designed, manufactured, and/or approved by Tuff Built Products Inc. **MUST BE** designed, installed, and used under the supervision of a Qualified Person.

The standards governing different situations specify various anchorage requirements. However, at no time can the anchorage provide any less than the greater of:

- a 2:1 safety factor on the maximum arrest force (MAF) rating of any fall arrest system being used,
- a 4:1 safety factor on personnel working loads applied to the system,
- a 4:1 safety factor on material handling loads applied to the system.

Anchorage selected must meet applicable local requirements for anchorage strength.

All installations **MUST BE** used under the supervision of a Qualified Person.

4.2 COMPATABILITY OF CONNECTORS

Connectors used to connect components in the system must be compatible with each other to ensure sufficient strength and eliminate the risk of accidental disengagement or rollout during use. Connectors supplied with products designed, manufactured, and/or approved by Tuff Built Products Inc. will meet all applicable requirements for connectors. Any connectors not supplied by Tuff Built Products Inc. **MUST BE** selected and approved by a Qualified Person.

4.3 FULL BODY HARNESS

Use only a full body harness designed, tested, and approved for fall arrest when connecting a person to this winch. Body belts or straps do not provide adequate support to the body to prevent serious injury or death in the event of a fall.

4.4 FALL PROTECTION

Activities involving working at heights require the use of equipment to protect the worker in the event of a fall. Suitable fall protection must be provided as required by applicable local regulations when using this winch.

4.5 CONFINED SPACE SAFETY

When this winch is use as part of a system involving work in a confined space, always follow an approved confined space safety plan meeting all local regulations.

4.6 SWING ANGLE

Care must be taken at all times to minimize the potential for swing fall when working at heights. At no time should the angle of the winch line exceed 5 degrees with respect to the vertical (see Figure 3).

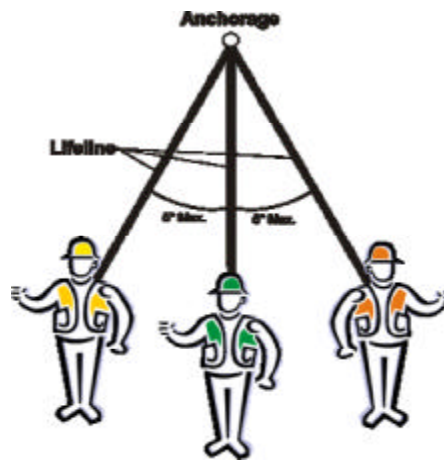

Figure 3, Maximum Swing Angle



5. WINCH INSTALLATION and OPERATION

5.0 INTRODUCTION

This winch is designed for use in conjunction with various styles of support structures to meet different requirements. These include tripods, davits, and pole hoists as well as a variety of special applications or custom structures. This product is intended for use only with products designed, manufactured and/or approved by Tuff Built Products Inc. Other applications must be designed, installed, and used under the supervision of a Qualified Person. All installations must be approved by a Qualified Person.

5.1 WINCH INSTALLATION

This winch may be used in conjunction with a wide variety of accessory products. Please refer to the Operator's Manual provided with all Tuff Built Products Inc. accessories at the time of purchase for detailed information on the installation of the winch onto the system.

For systems not supplied by Tuff Built Products Inc. the Qualified Person responsible for the design, installation, and use of the system must provide detailed information regarding the installation of the winch onto the system.

5.2 WINCH OPERATION

Once the winch has been properly installed into the system, the operation of the winch is as outlined below. No person shall use this winch without receiving proper training as outlined in Section 6. Any user must fully read and understand this manual and any other instruction manual(s) related to the system being used, or have the instructions explained to them, before using this equipment.

5.2.1 INSPECTION

This winch must be inspected before each use as outlined in Section 7.1. Daily inspection instructions are also given on the label on the handle-side cover of the winch (see Figure 4).

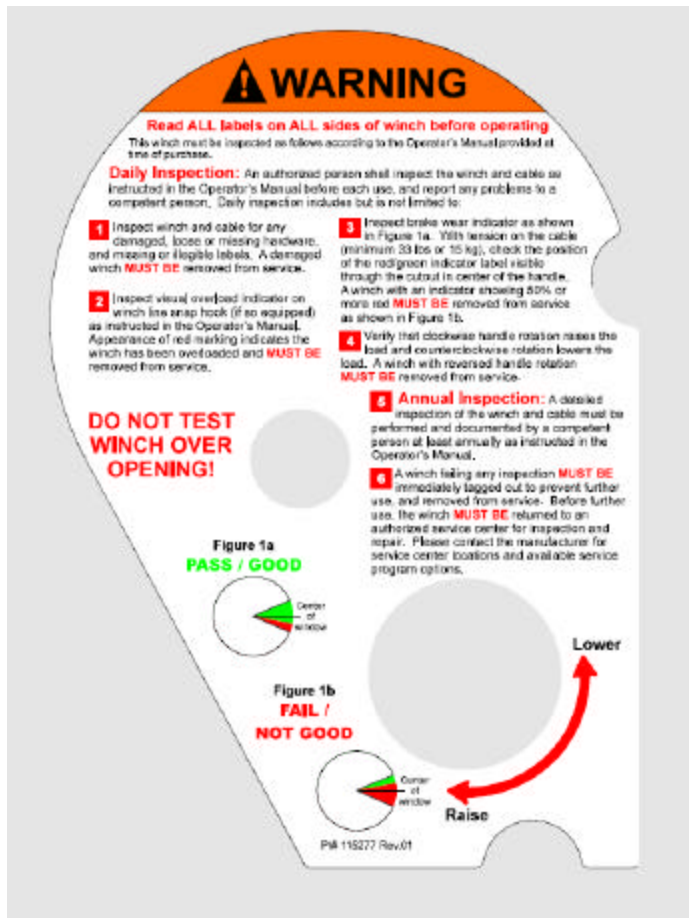

Figure 4, Daily Inspection Instructions

Any problems must be reported immediately to your supervisor, and the equipment labeled so as to prevent further use until it has been repaired.

5.2.2 ATTACHING A WORKER TO THE WINCH LINE

Any worker who is connected to this winch MUST wear a full body harness designed, tested, and approved for fall arrest. The winch line MUST be connected to the dorsal (rear) D-Ring on the harness, unless otherwise instructed by a qualified person.

Extend sufficient winch line to allow the line to be easily attached to the worker's dorsal D-Ring. Be sure to maintain sufficient tension in the line to prevent "bird-nesting" of the winch line.

Attach the winch line to the worker's dorsal D-Ring, making sure that the snap hook operates smoothly and fully locks when attached.

Retract the winch line until the line is snug, and have the worker slowly lift their feet off the ground to verify system integrity.

**** DO NOT TEST SYSTEM INTEGRITY OVER AN OPENING OR WHERE THERE IS A CHANCE OF FALLING****



5.2.3 RAISING OR LOWERING A WORKER

A worker attached to the winch line is lowered by cranking the winch handle counterclockwise, and raised by cranking the winch handle clockwise. DO NOT use the winch if the rotation of the winch handle is reversed, or if the winch does not make a regular clicking sound when cranking the winch handle in a clockwise direction.

Crank the handle at a smooth and steady pace that you find comfortable to maintain.

Wear gloves if your hands will come in contact with the winch line.

Maintain sufficient tension on the winch line, either from the weight of the worker or manually, to ensure that the line winds evenly onto the spool. Do not allow any slack line to accumulate between the winch and the worker if there is any risk of a fall occurring. Serious injury or death may result if a worker falls while connected to a slack winch line.

6. TRAINING

Prior to working with this winch all users must receive training from their employer on all equipment involved, as well as appropriate training in Fall Protection, Confined Space, Rescue, Material Handling, General Safety and any other specific area necessary to safely complete the assigned work.

Users must fully read and understand this manual and any other instruction manual(s) related to the system being used, or have the instructions explained to them, before using this equipment.

7. INSPECTION

7.1 DAILY INSPECTION

The winch must be inspected before each use as described in Sections 7.1.1 to 7.1.5. Report any problems or concerns to your supervisor, and do not use the equipment until they have approved doing so.

7.1.1 Cleaning and Lubrication

If required, clean and lubricate the winch and all its parts as outlined in Section 8. Do not use solvents or other chemicals to clean the winch.

7.1.2 Physical Damage

Inspect the winch, winch line, snap hook, and mounting brackets for physical damage; bent parts, cracked housings, dented covers, loose or missing hardware or parts, missing, or illegible labels (see Figure 5). Replacement labels are available from your dealer by ordering the part number shown on each label.

Note: Not all labels shown may be present on your winch, as some are related to standards and certifications that may not apply to your jurisdiction.

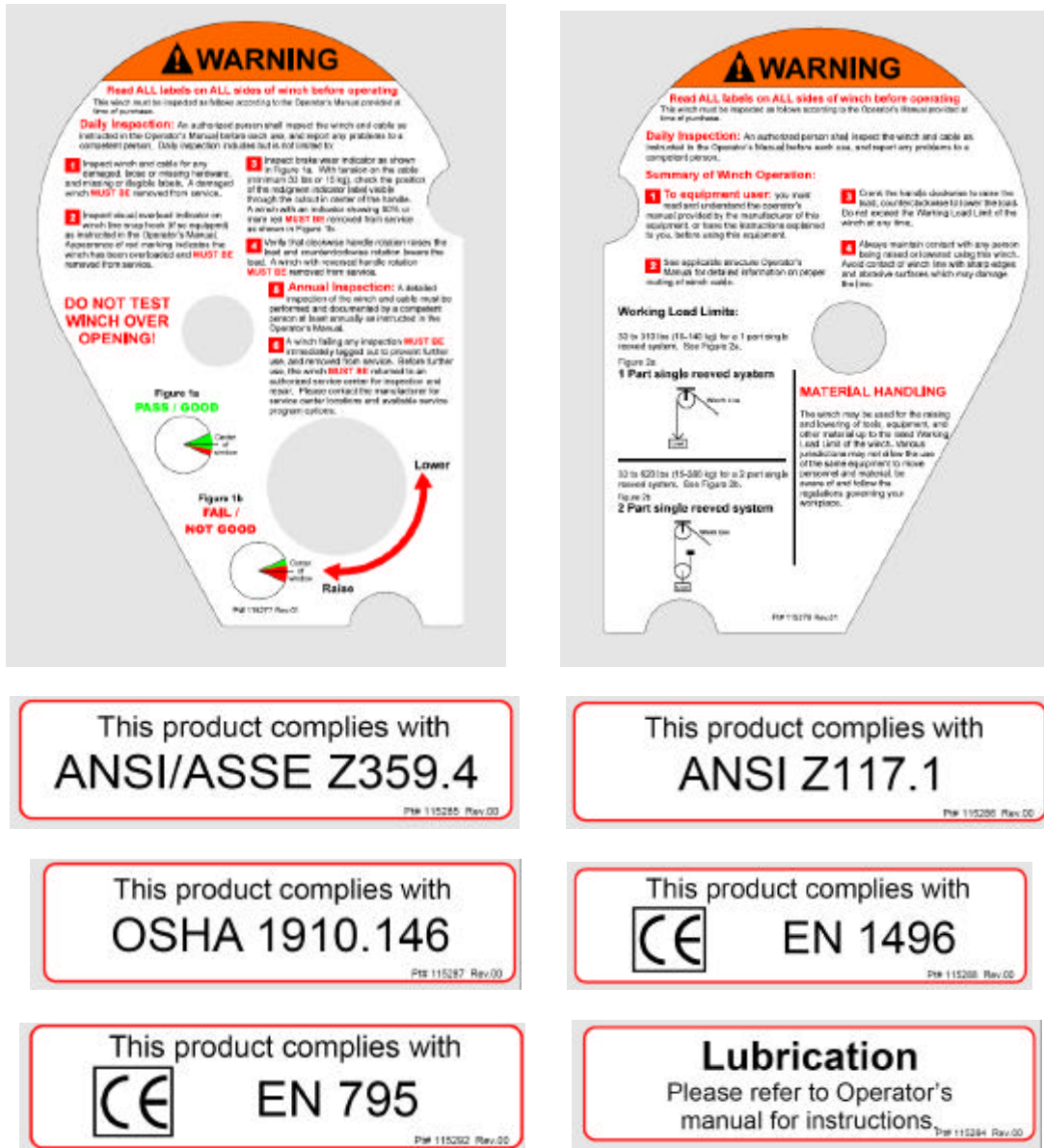

Figure 5, Winch Labels (continued next page)

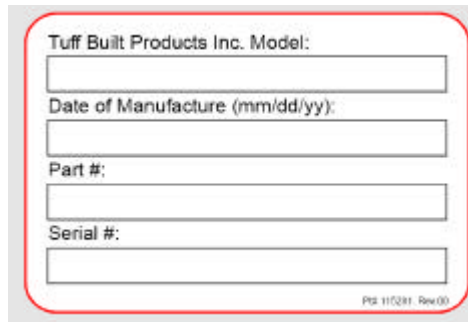
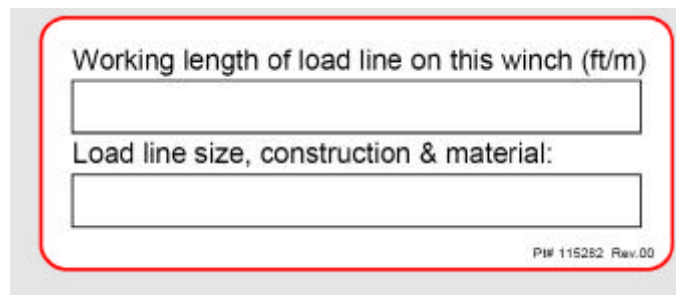

Figure 5, Winch Labels (continued)

While minor cosmetic damage will not impair the function of the winch, a seriously damaged winch **MUST** BE removed from service and returned to an authorized service center for repair prior to further use.

7.1.3 Overload Indicator Activation

Inspect the visual Overload Indicator on the snap hook (Figure 6a) to ensure that the winch has not been overloaded. If a red band is visible as shown in Figure 6b, the winch has been overloaded. A winch which has been overloaded **MUST BE** removed from service and returned to an authorized service center for repair prior to further use.



Figure 6a



Figure 6b

Figure 6, Snap Hook Overload Indicator

7.1.4 Brake Wear Indicator Reading

Inspect the brake wear indicator as shown in Figure 7. With a minimum 33lbs (15kg) tension on the cable, check the position of the red/green indicator label visible through the cutout in the center of the handle. A winch with an indicator showing 50% or more red **MUST BE** removed from service and returned to an authorized service center for repair prior to further use.

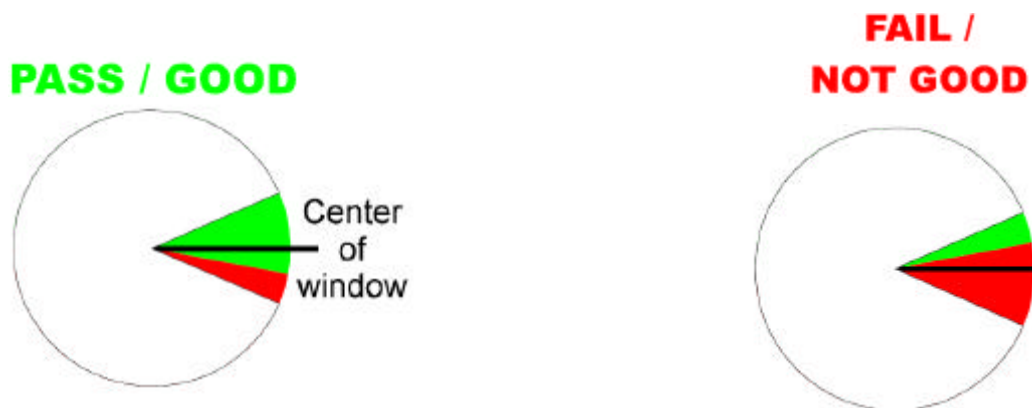

Figure 7, Inspection Criteria for Brake Wear Indicator

7.1.5 Crank Handle Rotation Direction and Ratchet Operation

Check the direction of crank handle rotation to verify that the winch line is extended by cranking the winch handle counterclockwise, and retracted by cranking the winch handle clockwise (see Figure 7). If the rotation of the winch handle is reversed, or the winch does not make a regular clicking sound when cranking the winch handle in a clockwise direction, it **MUST BE** removed from service and returned to an authorized service center for repair prior to further use.



Figure 8, Crank Handle Rotation Direction

7.2 ANNUAL INSPECTION

At least annually, and more frequently if subjected to harsh conditions or excessive use, this winch **MUST BE** given a detailed inspection by a competent person as described below, and the results recorded in an Inspection Log. A sample Inspection Log is provided on Pages 26 & 27 of this manual, please make photocopies of this sample to record all inspection results.

NOTE: Any time a winch is returned to a factory authorized service center for repair, please provide photocopies of all previous Inspection Log sheets for that winch to assist with diagnosis and processing of any warranty claims.

Please obtain a Returned Goods Authorization number from the service center before sending your winch for service.

7.2.1 Cleaning

Prior to this inspection, clean the exterior surfaces of the winch with a mild soap solution on a soft cloth. Do not use solvents or other chemicals to clean the winch.

7.2.2 Inspection Procedure

Following the instructions contained in Section 7.1.2, 7.1.4, and 7.1.5 respectively, inspect the winch for physical damage, brake wear indicator reading, and crank handle rotation direction. Record the results in the Inspection Log.

Inspect the condition of the winch line snap hook as described in Section 7.2.3, and record the results on the Winch Inspection Log sheet.

Additionally, a detailed inspection of the winch line must be performed as described in Section 7.2.4 (for wire rope winch lines), or 7.2.5 (for synthetic rope winch lines) and the results recorded on the Winch Line Inspection Log sheet.

IMPORTANT: Be sure to review any previous inspection records to be aware of existing winch line concerns and to allow for re-inspection of any potential problem areas. Cumulative findings may lead to the need for winch line replacement when looked at together.

7.2.3 SNAP HOOK INSPECTION

- Inspect the condition of the Overload Indicator on the snap hook as outlined in Section 7.1.3. A winch which has been overloaded **MUST BE** removed from service and returned to a factory authorized service center for repair.
- Inspect the condition of the snap hook (Figure 6a) for any mechanical damage, bent, missing, or corroded parts. Any winch with a damaged snap hook **MUST BE** removed from service and sent to a factory authorized service center for repair.
- Check the function of the locking mechanism for free operation, and make sure that the gate cannot be opened without first depressing the keeper. Lubricate the mechanism with light oil as instructed in Section 8.2.3. If the locking mechanism does not operate freely after lubrication, the winch **MUST BE** removed from service and sent to a factory authorized service center for repair.
- Ensure that the swivel rotates freely, and lubricate with light oil as instructed in Section 8.2.3. If the swivel does not operate freely after lubrication, the winch **MUST BE** removed from service and sent to a factory authorized service center for repair.
- Inspect the thimble, ferrules, and winch line forming the eye holding the snap hook for any wear, cuts, fraying, broken wires, or other damage. If there is any damage to the connecting hardware, or there is any winch line damage adjacent to the eye, the winch **MUST BE** removed from service and sent to a factory authorized service center for repair.

7.2.4 WIRE ROPE WINCH LINE INSPECTION

If the winch you are inspecting is equipped with a wire rope winch line, inspect the wire rope as follows and document the findings in the Rope Inspection Log.

7.2.4.1 Introduction to Wire Rope Terminology

Before discussing wire rope inspection criteria you need to understand the basic construction of wire rope and the terms used to describe it (see Figure 9). Wires (a) are the individual elements that make up a wire rope. A number of wires are laid together to form strands (b), and then a number of strands are laid together around the core (c) to form the wire rope (d).

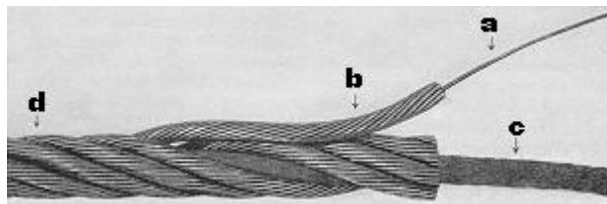

Figure 9, Wire Rope Construction

The lay length is defined as the distance along the wire rope that it takes a strand to completely move around the core (see Figure 10).

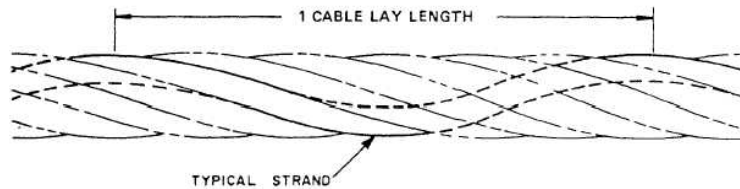

Figure 10, Lay Length

These terms are used to define the criteria for accepting or rejecting a wire rope winch line for continued service.

7.2.4.2 Wire Rope Inspection Procedure

-Have a helper slowly crank the winch so as to pay out the entire length of the wire rope while maintaining approximately 33 lbs (15kg) tension on the line. Use a stiff wire brush to clean any built up lubricant and other contaminants from the cable as you are winding it off the drum. Carefully inspect the attachment point of the wire rope to the winch drum for any wear, fraying, loose fittings, or other damage.

- Wear heavy gloves to prevent injury from any loose or broken wires, and inspect the wire rope along its entire length by running it through your hands while visually checking its condition. Flexing the cable can help expose hidden damage. Look for any of the types of damage as shown in Figures 10, 11, 12, 13, 14, 15:



Figure 10, Core Protrusion, Indicating Shock Loading



Figure 11, Crushing of the Wire Rope



Figure 12, Corrosion of the Wire Rope



Fatigue (Reverse Bend)



Fatigue (Undersized Sheave)

Figure 13, Fatigue Damage Resulting in Broken Wires



Figure 14, Abrasion Damage

Bulges or reduction in diameter (See Figure 15).

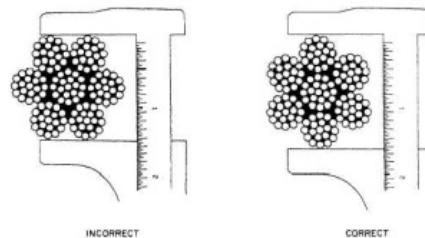

Figure 15, Measuring the diameter of a wire rope.

A wire rope with flattened sections where the diameter across the damaged section is less than five sixths of the original diameter **MUST BE** removed from service and sent to a factory authorized service center for repair.

Also look for:

-Heat damage or electrical arc damage (indicated by blue or other discoloration, melting, weld spatter, or apparent loss of lubrication),

-Excessive contamination which can prevent lubrication from penetrating the wire rope, increasing internal friction and corrosion

A wire rope winch line exhibiting any of the above conditions **MUST BE** removed from service and sent to a factory authorized service center for repair.

The presence of one or more broken wires in one rope lay length or one or more broken wires near an attached fitting is cause for replacement.

If a broken wire is the result of corrosion or if the wire rope is excessively corroded, the cable must be replaced. Corrosion often develops from the inside out and may have seriously weakened the wire rope by the time it becomes visible.

Location of all broken wires **MUST BE** recorded in the Winch Line Inspection Log for reference during future inspections.

The protruding end of any broken wires should be removed as they occur by bending backwards and forwards using a pair of pliers until they break deep in the valley between two outer strands. Wear gloves and protective eyewear during this operation.

Before re-installing the wire rope on the drum, inspect the surface of the drum spool, grooves and side plates for any nicks, gouges, or other wear that could damage the wire rope.

When winding the wire rope back onto the drum, ensure that you rotate the winch crank handle clockwise to retract the line, and that the ratchet mechanism produces a regular clicking sound while cranking (See Section 7.1.5). Lubricate the cable with light oil, and use a clean cloth to wipe off the excess as you wind it onto the drum as described in Section 8.2.2.

Record findings of any of the above conditions on the Winch Line Inspection Log sheet, remove the winch from service and make arrangements to have it sent to a factory authorized service center for repair.

7.2.5 WINCH LINE INSPECTION (SYNTHETIC ROPE)

If the winch you are inspecting is equipped with a synthetic rope winch line, inspect the rope as follows and document the findings in the Inspection Log.

7.2.5.1 Introduction to Synthetic Rope Winch Line Inspection

IMPORTANT: Synthetic ropes are difficult to inspect and assess accurately. Internal damage, UV degradation, chemical contamination, and age related deterioration are hard to see and can vary widely with rope material, construction, and manufacturer. If there is any doubt about the condition of a rope, the winch **MUST BE** removed from service and sent to a factory authorized service center for repair.

7.2.5.2 Synthetic Rope Inspection Procedure

-Have a helper slowly crank the winch so as to pay out the entire length of the rope while maintaining approximately 33 lbs (15kg) tension on the line. Carefully inspect the attachment point of the rope to the winch drum for any wear, cuts, fraying, separation, or other damage.

-Inspect the rope along its entire length by running it through your hands while visually checking its condition. Look for any:

-Knots (a knot in a rope may reduce its strength by 50% or more),

-Cuts longer than 1/32" (1mm),

-Heat or friction damage (indicated by discoloration, glazing, softness or hardness of the fibres),



-Abrasion or other wear, especially if localized. For a braided rope there should be no more than 25% wear from abrasion, for a 3-strand rope, no more than 10%.

-UV Degradation (indicated by loss or change of color or a powdery surface),

-Chemical damage (indicated by discoloration, softening, or flaking of the surface)

-Inconsistent diameter, flat areas, bumps, or lumps indicating core or internal damage from overloading or shock loading,

-Before re-installing the rope on the drum, inspect the surface of the drum spool, grooves and side plates for any nicks, gouges, or other wear that could damage the rope.

-When winding the rope back onto the drum, ensure that you rotate the winch crank handle clockwise to retract the line, and that the ratchet mechanism produces a regular clicking sound while cranking (See Section 7.1.5).

Record findings of any of the above on the Winch Line Inspection Log sheet, remove the winch from service and make arrangements to have it sent to a factory authorized service center for repair.



8. MAINTENANCE, LUBRICATION and STORAGE

This winch has been designed to provide many years of trouble free service, and requires little in the way of routine maintenance.

Any loose fasteners should be tightened, with the winch being sent to a factory authorized service center for repair if necessary.

Basic cleaning should be performed at least annually (as outlined in Section 8.1) as part of the annual inspection or more frequently as required when used is under harsh conditions.

Lubrication of the wire rope (if so equipped), snap hook, crank handle knob, and brake pads should be performed at least annually (as outlined in Section 8.2) as part of the annual inspection, or more frequently as required to maintain winch performance under harsh conditions.

8.1 Cleaning the Winch

Use a solution of warm water and a mild detergent to clean the exterior surfaces of the winch and the winch labels. Do not soak or submerge the winch, as internal corrosion or other damage may result. Clean the cable with a stiff wire brush as required, and lubricate outlined in Section 8.2. Do not use solvents or other cleaners to clean a wire rope, as this may remove internal lubrication.

8.2 Lubrication

8.2.1 Brake Pad Lubrication

To lubricate the brake pads in the winch, hold the spool from turning and rotate the crank handle counterclockwise at least 10 revolutions to completely disengage the brake mechanism. While continuing to rotate the crank handle counterclockwise, spray WD-40 (or other lubricant as approved by Tuff Built Products Inc.) around where the crank handle hub enters the winch housing.

8.2.2 Wire Rope Lubrication

After cleaning and inspection as instructed in Section 7.2.4, lubricate the wire rope with light oil, and use a clean cloth to wipe off the excess as you wind it onto the drum.

8.2.3 Snap Hook Lubrication

After cleaning and inspection as instructed in Section 7.2.3, lubricate the locking mechanism and swivel with light oil and wipe away any excess with a clean cloth.

8.2.4 Crank Handle Knob Lubrication

Lubricate the crank handle knob with light oil as required, and wipe away any excess with a clean cloth.

8.3 Storage

Store this winch and other related safety equipment out of direct sunlight in a cool, dry area away from dust, chemicals or other harmful material. Always inspect before using equipment that has been stored for any extended period of time.

9. SPECIFICATIONS

This winch is constructed primarily of zinc-plated steel, with an additional sealant coating applied for greater corrosion resistance. Stainless steel and various other materials are used in strategic locations.

The outer covers are impact-resistant die molded plastic.

This winch may be equipped with various different sizes and types of winch lines, including:

- Technora ropes from 3/16" (5mm) to 1/4" (6mm) diameter,
- Kernmantle ropes from 5/16" (8mm) to 5/8" (16mm) diameter, and
- Wire ropes from 3/16" (5mm) to 5/16" (8mm) in either galvanized steel or stainless steel.

Please check the Winch Line Details label (See Figure 16) for detailed information for the winch line supplied with your winch.

Working length of load line on this winch (ft/m)

Load line size, construction & material:

PI# 115282 Rev.00

Figure 16, Winch Line Details

The standard winch weighs 26 lbs (12 kg) without cable or mounting brackets.



WINCH INSPECTION LOG

Winch Model Number: _____

Winch Serial Number: _____

Date of Manufacture (dd/mm/yy): _____

Purchase Date (dd/mm/yy): _____

INSPECTION ITEM	PASS	FAIL	DETAILS / LOCATION of DAMAGE	DISPOSITION (REPAIRED / SCRAPPED)	APPROVED FOR USE BY
Physical Damage to Winch or Mounting Brackets (Missing, Loose, or Damaged Parts or Fasteners, Damaged, Missing or Illegible Labels)					
Brake Wear Indicator Reading					
Correct Crank Handle Rotation (Clicking Noise When Cranking Clockwise)					
Snap Hook Condition (Section 7.2.3)					

Date of Inspection: _____

Inspected By: _____



WINCH LINE INSPECTION LOG

Winch Model Number: _____

Winch Serial Number: _____

Winch Line Type, Size, Material, and Construction _____

Inspection Checklist for Wire Ropes (See Section 7.2.4)

	Location of Defect (from winch drum)	Pass	Fail	Disposition
Condition of Winch Line Attachment to Drum	N/A			
Core Protrusion				
Crushing Damage				
Corrosion / Chemical Damage				
Broken Wires (Fatigue Damage)				
Abrasion Damage / Broken Wires				
Bulges in Wire Rope Diameter				
Reduction in Wire Rope Diameter				
Heat / Electrical Arc Damage				
Excessive Contamination				

Inspection Checklist for Synthetic Ropes (See Section 6.2.5)

Inspection Criteria (Synthetic Ropes)	Location of Defect (from winch drum)	Pass	Fail	Disposition
Condition of Winch Line Attachment to Drum	N/A			
Knots				
Cuts				
Heat / Friction Damage				
Abrasion Damage				
UV Degradation				
Chemical Damage				
Overloading / Shock Loading Damage				

Date of Inspection: _____

Inspected By: _____