

USER INSTRUCTION MANUAL: N-800 BEAM ANCHOR

WARNING: User must understand the manufacturer's instructions and be trained in the proper use of e. Manufacturer's instructions must be followed for proper installation, use, care, and maintenance of this product. These instructions must always be available for reference. Alterations or misuse of this product or failure to follow instructions may result in serious injury or death.

IMPORTANT: This manual is intended to meet the Manufacturer's Instructions as required by the American National Standards Institute (ANSI) Z359.18-2017 and should be used as part of an employee training program as required by the Occupational Safety and Health Administration (OSHA). All components or subsystems used with the beam anchor discussed in this manual must be in compliance with ANSI Z359 and OSHA.

1.0 WARNINGS REGARDING THE BEAM ANCHOR:

- Before use, all users must understand the instructions, operation, limitations, and consequences of improper use of device.
- Before use, all users must be properly trained in accordance with the requirements of OSHA 29 CFR 1910.66 and 1926.503 or applicable local standards in the safe use of the fall arrest system and its components.
- Before use, thoroughly inspect the beam anchor as indicated in Section 8.
- Only use the N-800 beam anchor with ANSI/OSHA compliant personal fall arrest or restraint systems.
- In the absence of certification, the anchorage must be capable of supporting a static load, applied in the directions permitted by the system, of at least 5,000-lbf (22kN).
- The user shall be equipped with a means of limiting the maximum dynamic forces exerted on the user during the arrest of a fall to a maximum of 8 kN (1800-lbf).
- A competent engineer or other qualified person must approve that the use of N-800 beam anchor is compatible with all structural and operational characteristics of the selected installation location and system that it will relate to.
- Prior to each use, the N-800 must be inspected for wear, damage, and other deterioration. The beam anchor must immediately be removed from service (in accordance with OSHA 29 CFR 1910.66 and 1926.502) if it does not pass inspection.
- Before use, ensure that the complete fall protection system (including components, fall clearance, and swing fall) are planned and established correctly.
- Position the beam anchor in such a way to minimize the potential for falls, and the fall distance during use.
- Before use, establish a rescue plan that provides either: prompt rescue of users in the event of a fall, or assures users can rescue themselves. Also confirm that the means to implement said rescue plan are at hand and easily accessible.
- After a fall, the anchorage connector must be removed from service and destroyed immediately.

2.0 WARNINGS REGARDING WORKING AT HEIGHT:

- Before use, consult your doctor to ensure that your physical condition allows you to safely withstand the impact of all forces involved with working at height.
- Do not use any fall protection equipment that has failed inspection.
- Ensure all connections are compatible, and that all subsystem combinations do not interfere with the function of this device.
- Ensure that a written rescue plan, and the means to implement it, are always available when using this device. For more information, refer to ANSI Z359.4-2013 and Z359.2-2017.
- Immediately seek medical attention for the affected party if a fall event occurs.
- When inspecting, installing, or using the device / system, always ensure that you wear appropriate Personal Protective Equipment.
- Never exceed: maximum free fall distance and allowable capacity for your fall protection.
- Never expose workers to fall hazards during training.

3.0 WARNINGS REGARDING USE LIMITATIONS:

- This device must not be used outside its limitations, or for any purpose other than for which it is intended.
- The device must only be coupled to compatible connectors
- Per OSHA 29 CFR 1926.502, snaphooks should not be engaged to objects unless: it is a locking type snaphook, and it is "designed for" making such a connection. "Designed for" means that the manufacturer of the snaphook specifically designed the snaphook to be used to connect to the equipment listed.
- User capacity: single user only, with weight up to 310 lbs (140 kg), including tools, clothing, etc.
- User environment temperature range: -30°F to +130°F (-34°C to +54°C).
- Do not expose the beam anchor to chemicals or solutions which may result in a harmful effect
- Do not alter or modify this product in any way.
- Exercise caution when using any component of a fall protection system near hazards such as: moving machinery, electricity, sharp edges, and abrasive surfaces. Failure to do so may result in equipment failure, personal injury or death.
- All individuals must be trained by a "competent person" (as defined by OSHA 29 CFR 1926.32(f)) before using this equipment
- Do not remove the labeling from this product.
- Depending on anchorage type / type of fastening used for installation, there may be additional requirements or limitations. Before installation, all placements must be approved by a competent engineer or other qualified person.
- Do not use this beam anchor as part of a horizontal lifeline system that has not been designed and approved for use with 5,000-lbf anchorage connectors.
- The anchorage connector should only be used for personal fall protection (not lifting).
- Per ANSI Z359.0-2007, rollout is when a snaphook or carabiner unintentionally disengages from another connector or object to which it is coupled. When a non-locking carabiner is used, the following connections could result in rollout:

Rollout may result in equipment failure, personal injury or death.

- Direct connection of a snaphook to horizontal lifeline.
- Two (or more) snaphooks connected to one D-ring.
- Two snaphooks connected to each other.
- A snaphook connected back on its integral lanyard.
- A snaphook connected to a webbing loop or webbing lanyard.
- Improper dimensions of the D-ring, rebar, or other connection point in relation to the snaphook dimensions that would allow the snaphook keeper to be depressed by a turning motion of the snaphook.

4.0 DESCRIPTION:

4.1 KEY COMPONENTS: Refer to Figure 1 for identification of key components of **Safety Direct** beam anchor.

- **A:** Adjustable Hook
- **B:** Swivel Ring
- **C:** Rod with Inserted Notches
- **D:** Push Button for Adjusting

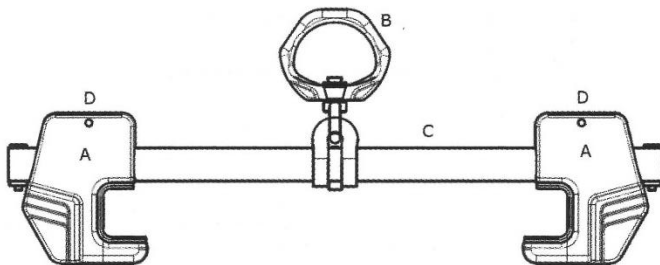

Figure 1: Key components of beam anchor.

4.2 SPECIFICATIONS:

- **Weight:** 3.5 lbs
- **Beam Flange Thickness:** 0.25" – 1.25"
- **Beam Flange Width Range:** 3.5" – 14"
- **Minimum Breaking Strength:** 5000 lbs (22 kN)
- **Maximum Capacity:** 310 lbs
- **ANSI Compliance:** Z359.18 Type A, Z359.7-2011
- **OSHA Compliance:** 1926.502, 1910.66

4.3 MATERIALS:

- **Adjustable Hooks:** Aluminum
- **Swivel Ring:** Steel
- **Rod:** Aluminum
- **Notches:** Aluminum
- **Push Button:** Steel

5.0 INSTALLATION:

5.1 PLANNING: Before use, ensure that you plan your fall protection system considers all limitations and factors that may affect your safety before, during, and after a fall as outlined in this instruction manual.

5.2 ANCHORAGE:

- Use a structural steel beam flange capable of withstanding a 5,000 lbf. Static load or meeting OSHA 1926.502 requirements for a safety factor of two.
- Push in on the push button to allow the adjustable hook to move.
- Fit the hooks over the edge of the beam flange while keeping the unit perpendicular to the beam.
- Slide the adjustable hook so that both hooks snug against the beam flange.
- Release push button to ensure the ratchet teeth are fully seated in the closest ratchet notches.
- Ensure the beam anchor cannot detach from the flange by tugging, rocking, and twisting it in all directions.
- When moving to a new or different sized beam, user must re-adjust according to above installation steps.

IMPORTANT: For ease of sliding, the d-ring is centered on the anchorage connector. In some loading conditions (particularly in rope access applications), bodyweight may disengage the centering feature. This is not a safety concern, but it may affect usability.

5.3 COMPATIBILITY OF COMPONENTS:

- Connectors (hooks, carabiners, and D-rings) and connecting elements are compatible when their sizes and shapes do not cause gate mechanisms to unintentionally open.
- Use the beam anchor with approved components and subsystems only. Using the beam anchor with non-approved components and subsystems may interfere with the safety and reliability of the complete system.
- The user shall be equipped with a means of limiting the maximum dynamic force exerted on them during the arrest of a fall to a maximum of 8 kN (1,800 lbf). In the EU, this force must be limited to 6 kN (1,350 lbf).

6.0 USER DIRECTION / ORIENTATION:

6.1 ADJUSTABLE DIRECTIONS: Refer to Figure 2 for hook adjusting directions.

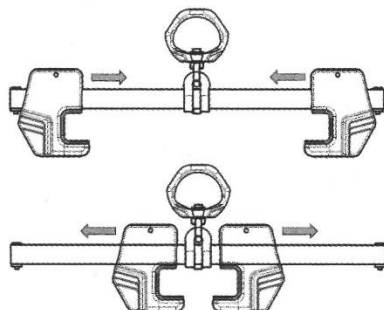

Figure 2: Adjustable Directions

6.2 LOADING DIRECTIONS: Refer to Figure 3.

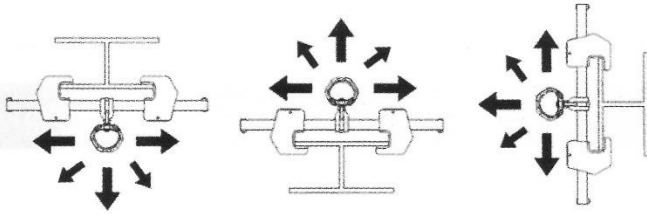
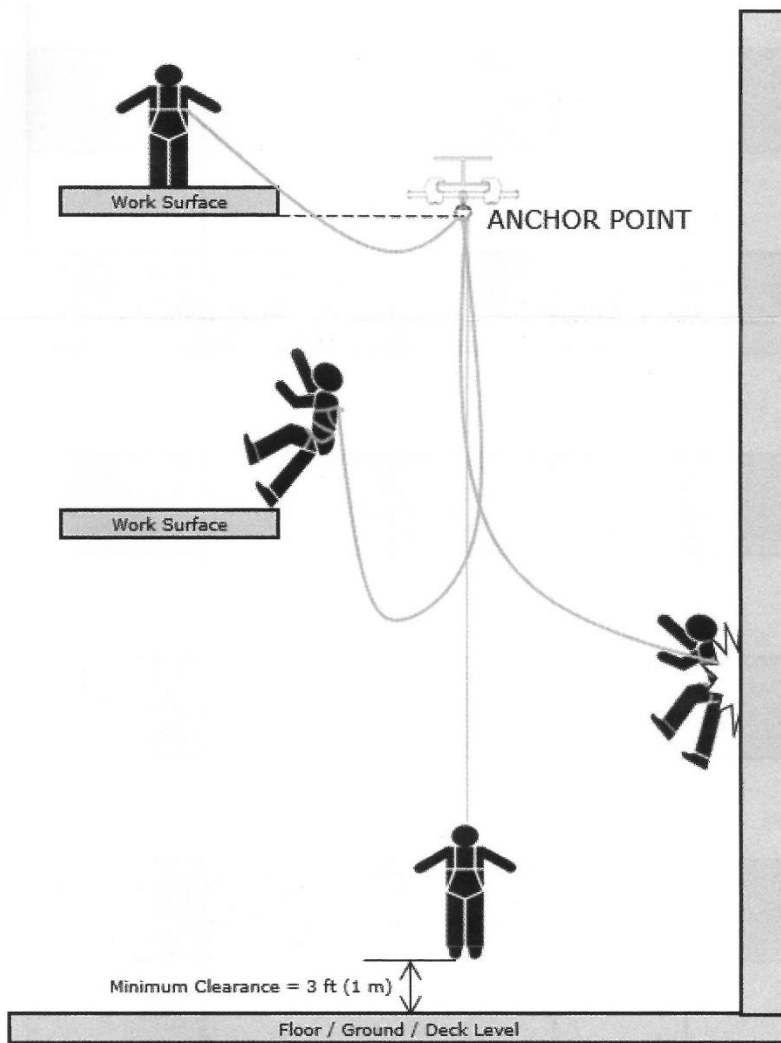

Figure 3: Loading Directions

IMPORTANT: The beam anchor must be attached to the I-beam flange that faces the user (top flange if above, bottom flange if below, etc.). If the beam anchor is placed at or below the user's working height, it requires integration of a compatible ANSI Z359.1 shock-absorbing lanyard that does not allow the user to extend more than 6 feet (in any direction) from the anchorage connector before the shock absorber is activated.



IMPORTANT: All products subjected to fall arresting forces must be removed from service immediately after fall.

WARNING: Swing falls may occur when the user is not directly under anchor point.

7.0 WARNING LABEL

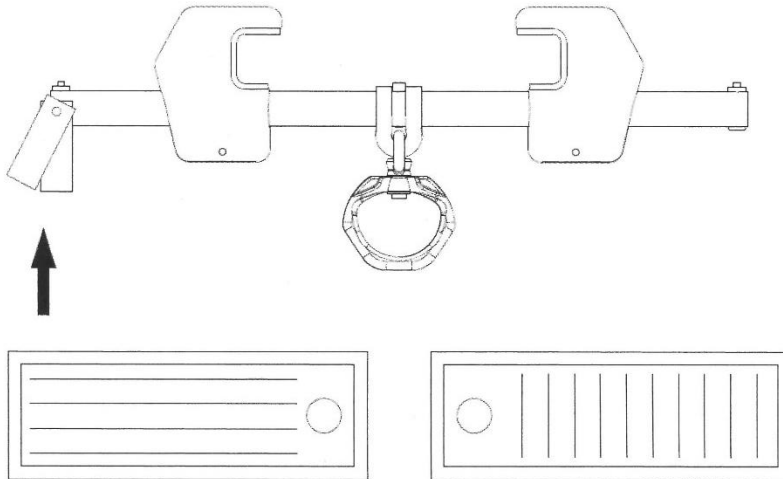

WARNING: It is important and necessary to the safety of the end user that the seller of this device include all instructions pertaining to the proper use, maintenance, and inspection of the device in the language of the country/region in which the device is to be sold.

8.0 INSPECTION

8.1 PRE-USE: Before each use, ensure each unit is in good working condition through inspecting as per instructions indicated in Table 1 below. Record results of inspection using the Inspection Record in Appendix A. Remove the unit from service if the unit exhibits damage, defects, inadequate maintenance, or any other unsatisfactory results during inspection.

Table 1 - Guidelines for Beam Anchor Inspection		
Inspection	Pass	Fail
Make sure all labeling is affixed to the unit.		
Inspect anchoring system for signs of damage or wear.		
Make sure swivel ring is free to swivel and pivot.		
Ensure hooks engage and disengage properly.		
Record final inspection results in the Inspection Record in Appendix A.		

8.2 INSPECTION FREQUENCY:

- Units must be inspected by a competent person at regular intervals, as required by the type of use and working environment. The competent person must use inspection criteria indicated in Table 1.
- Official periodic inspection must be made at least annually. This inspection must be performed by a competent person.
- If severe weather or conditions exist then inspections must be carried out more frequently.
- All inspection results must be recorded in the Inspection Record.
- It is recommended to mark the anchor with the date of the next or last inspection.

IMPORTANT: The beam anchor must be labeled as 'unusable' and promptly discarded if inspection indicates any damage that could affect the strength or operation of the device, or unsafe conditions.

9.0 STORAGE, SERVICE, AND MAINTENANCE

9.1 MAINTENANCE AND CLEANING:

- Ensure that the device is kept clean and free of debris that may interfere with the function of the latches (ie: grease, paint, dirt, etc).
- Periodic cleanings will prolong the life of this product. Cleaning frequency should be determined based on inspection and severity of the environment.
- Clean the beam anchor with compressed air and/or a stiff brush using water or a mild soap and water solution.
- Do not clean the beam anchor with corrosive chemicals, as these may damage the product.
- After cleaning, wipe all surfaces with a clean, dry cloth and hang unit to dry or use compressed air.

9.2 STORAGE:

- When not in use, store the device in a clean, dry, and cool environment, out of direct sunlight and free of corrosive or other degrading elements.
- Position the device in such a way that excess water is allowed to drain out.
- Avoid exposing device to chemical or caustic vapors.
- After a prolonged period of storage, thoroughly inspect the device.

9.3 SERVICE: The beam anchor is not user repairable. If the beam anchor does not pass pre-use inspection, tag as "UNUSABLE" and either (a) dispose of it, or (b) contact an authorized service center of **Safety Direct**.

APPENDIX A: INSPECTION RECORD

Inspection Record					
Model #: _____		Serial #: _____		Date of Manufacture: _____	
INSPECTION DATE	INSPECTOR	COMMENTS	PASS/FAIL	CORRECTIVE ACTION NEEDED	APPROVED BY